



Transport  
Canada

Transports  
Canada



# GRADE CROSSINGS STANDARDS

July, 2014

TABLE OF CONTENTS

<b>PART A – INTRODUCTION .....</b>	<b>3</b>
1 CITATIONS .....	3
2 INTERPRETATION .....	3
<b>PART B - EXISTING GRADE CROSSINGS.....</b>	<b>4</b>
3 CROSSING SURFACE .....	4
4 RAILWAY CROSSING SIGN AND NUMBER OF TRACKS SIGN .....	5
<b>PART C - NEW STANDARDS.....</b>	<b>10</b>
5 CROSSING SURFACE .....	10
6 ROAD GEOMETRY (GRADE CROSSINGS AND ROAD APPROACHES) .....	12
7 SIGHTLINES .....	14
8 SIGNS .....	17
9 WARNING SYSTEMS SPECIFICATION .....	24
<b>PART D – DESIGN CALCULATIONS .....</b>	<b>26</b>
10 DESIGN CONSIDERATIONS .....	26
11 LOCATION OF GRADE CROSSINGS.....	35
<b>PART E – WARNING SYSTEM DESIGN .....</b>	<b>36</b>
12 WARNING SYSTEM OPERATION - GENERAL.....	36
13 NUMBER AND LOCATION OF LIGHT UNITS .....	42
14 LIGHT UNITS - ALIGNMENT .....	45
15 BELLS AND GATES.....	45
16 CIRCUITRY .....	46
17 WARNING SYSTEMS AND TRAFFIC SIGNALS INSTALLED AT A GRADE CROSSING IN LIEU OF A WARNING SYSTEM - INSPECTION AND TESTING.....	48
<b>PART F – INTERCONNECTED DEVICES .....</b>	<b>51</b>
18 PREPARE TO STOP AT RAILWAY CROSSING SIGN .....	51
19 INTERCONNECTION OF TRAFFIC SIGNALS WITH A WARNING SYSTEMS .....	51
20 INTERCONNECTED DEVICES - INSPECTION AND TESTING .....	52
<b>APPENDIX A – LIGHT EMITTING DIODE (LED) SIGNAL MODULES .....</b>	<b>53</b>
<b>APPENDIX B - LIMITED USE WARNING SYSTEMS AND SIGNS.....</b>	<b>56</b>
<b>APPENDIX C - LIMITED USE WARNING SYSTEMS WITH WALK LIGHT .....</b>	<b>57</b>
<b>APPENDIX D – WHISTLING CESSATION.....</b>	<b>60</b>

## PART A – INTRODUCTION

### 1 CITATIONS

The following are the citations for documents referred to in the Standards:

“**62-GP-11M** is the standard for *Marking Material, Retroreflective Elements, Adhesive Backing*, 62-GP-11M, published by the Canadian General Standards Board (CGSB), dated May 1978 - as amended in July 1987 (Amendment No 1);

“**AREMA Communications and Signals Manual**” is the 2013 edition of the *Communications and Signals Manual of Recommended Practice*, published by the Communications and Signals Group of the American Railway Engineering and Maintenance of Way Association, in effect on December 31, 2013;

“**ASTM D4956**” is the 11<sup>th</sup> edition of the *Standard Specification for Retroreflective Sheeting for Traffic Control*, published by the American Society for Testing and Materials, dated March 30, 2011;

“**GCS**” means the *Grade Crossings Standards*;

“**Manual of Uniform Traffic Control Devices for Canada**” refers to the 4<sup>th</sup> ed. of the *Manual of Uniform Traffic Control Devices for Canada*, prepared by the Traffic Operations and Management Standing Committee, published by the Transportation Association of Canada, dated September 1998.

### 2 INTERPRETATION

The following definitions apply in this Standard:

“**crossing user**” means drivers of vehicles, pedestrians, cyclists and persons using assistive devices;

“**cross-product**” means the product of the average annual daily railway movements and the average annual daily traffic of vehicles on the road that pass across the grade crossing;

“**travelled way**” means that part of a road intended for vehicular use, excluding shoulders.

## PART B - EXISTING GRADE CROSSINGS

### 3 CROSSING SURFACE

- 3.1 The crossing surface must be of a width that is equal to the width of the travelled way and shoulders of the road, plus 0.5 m on each side, measured at right angles to the centreline of the road, as shown in Figure 3-1(a) or (b), as the case may be.
- 3.2 A flangeway must be provided between the gauge side of the rail and the road surface and must be between 65 mm and 120 mm wide, and between 50 mm and 75 mm deep.

**Figure 3-1 – Crossing Surface**

a)

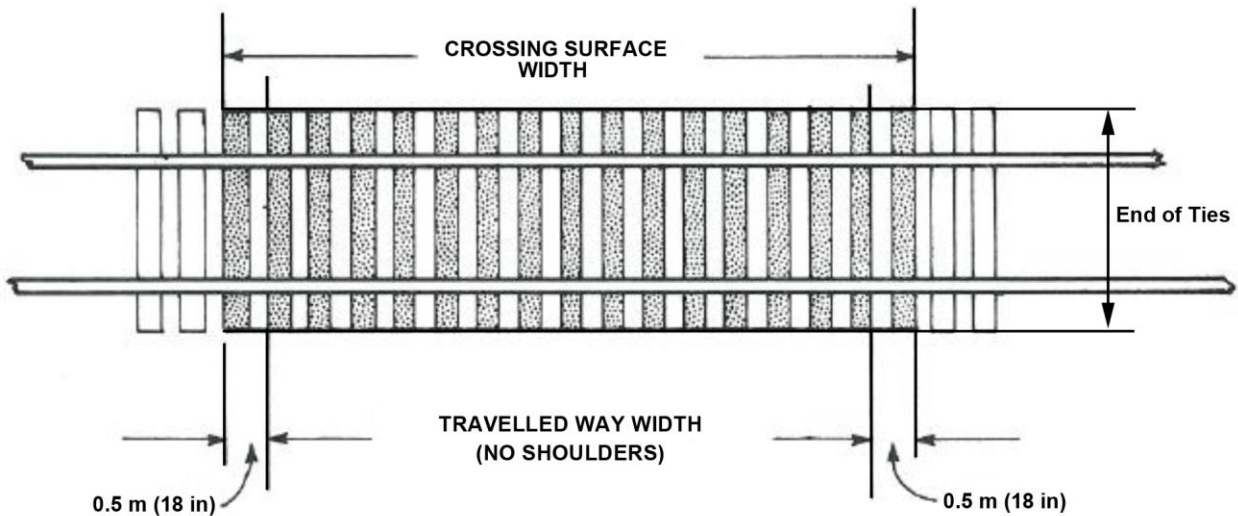

b)

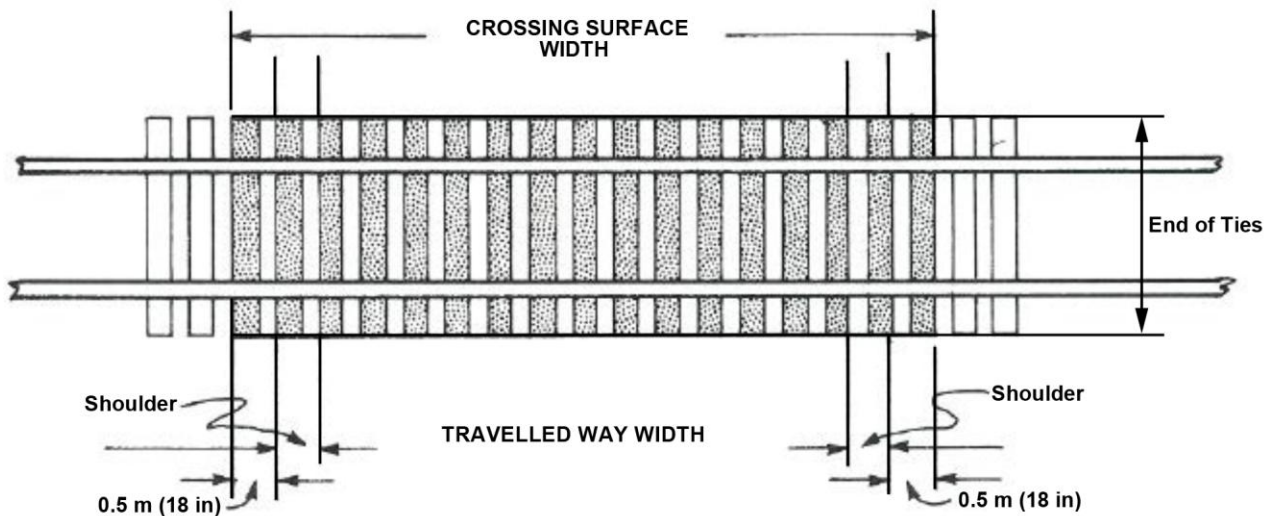

## Grade Crossings Standards, July 2014

### 4 RAILWAY CROSSING SIGN AND NUMBER OF TRACKS SIGN

- 4.1 A sign providing warning of a grade crossing (Railway Crossing sign) must have a 50 mm border of transparent red ink that is silk-screen processed over silver-white sheeting material, as shown in Figure 4-1(a). A sign indicating the number of tracks (Number of Tracks sign) must have a digit and symbol that is transparent red or black ink that is silk-screened processed over silver-white sheeting material, as shown in Figure 4-1(b).

#### 4.1.1 Without Warning Systems

A grade crossing without a warning system must have the following:

- (a) A railway crossing sign;
- (b) The railway crossing signs must be located as shown in Figure 4-2(a) and (b) and must be clearly visible to persons approaching the grade crossing on the road approach;
- (c) The railway crossing signs must be located between 0.3 m and 2.0 m from the face of curb, or outer edge of road approach shoulder; or, where there is no curb or shoulder, 2.0 m to 4.5 m from the edge of the travelled way;
- (d) The railway crossing signs must be located no closer than 3.0 m from the nearest rail;
- (e) Where there is more than one track at a grade crossing, an additional sign indicating the number of tracks to be crossed, must be installed on the supporting post of each railway crossing sign as shown in Figure 4-2(c).
- (f) A sidewalk, path or trail with its centreline more than 3.6 m (12 ft.) from a railway crossing sign supporting post beside a road approach for vehicle traffic must have separate railway crossing signs.

#### 4.1.2 With Warning Systems

A grade crossing with a warning system must have the following:

- (a) A railway crossing sign must be installed as shown in Figures 4-3 and 4-4.
- (b) Where there is more than one track at a grade crossing, a sign indicating the number of tracks to be crossed, as shown in Figure 4-1(b), must be installed on the supporting post of each railway crossing sign.

#### 4.1.3 Reflective Marking Material Specifications

- (a) The reflective material of the signs, referred to in 4.1, must cover the entire front surface of the signs.
- (b) The reflective material must meet the Level 2 reflective intensity values in Table 2 of the 62-GP-11M standard (cited in Part A).

# Grade Crossings Standards, July 2014

## Figure 4-1 – Railway Crossing Sign and Number of Tracks Sign

(a) RAILWAY CROSSING SIGN

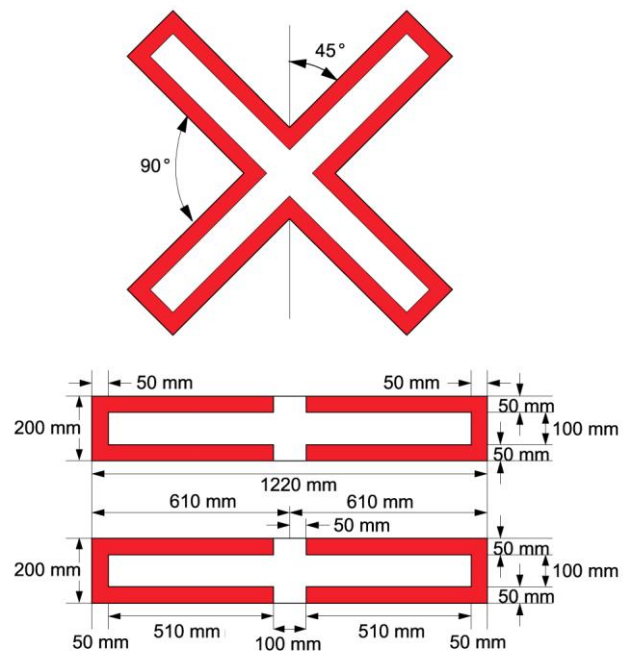

(b) NUMBER OF TRACKS SIGN

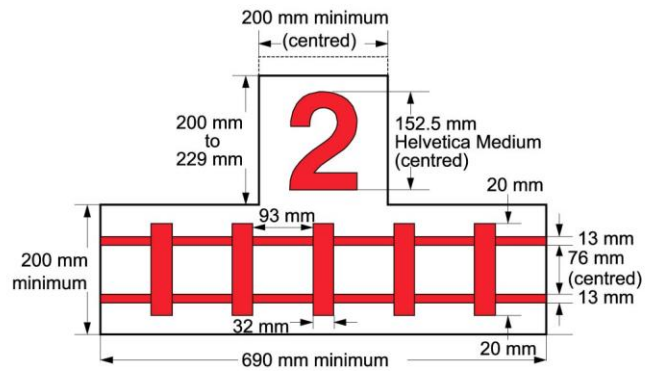

# Grade Crossings Standards, July 2014

**Figure 4-2 – Location of Railway Crossing Signs and Number of Tracks Signs (public grade crossings without warning systems)**

a)

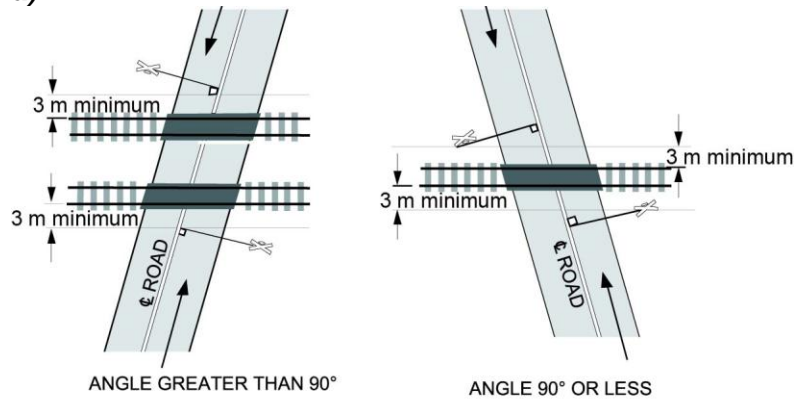

b)

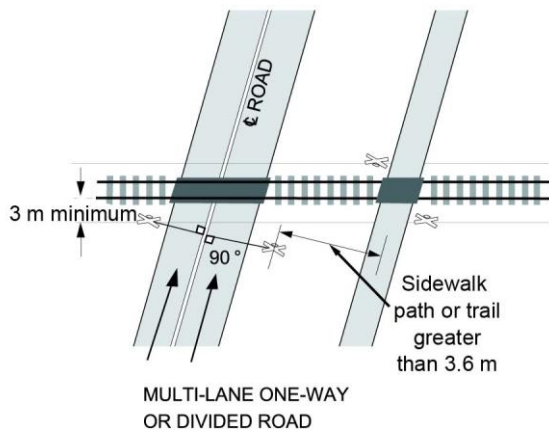

c)

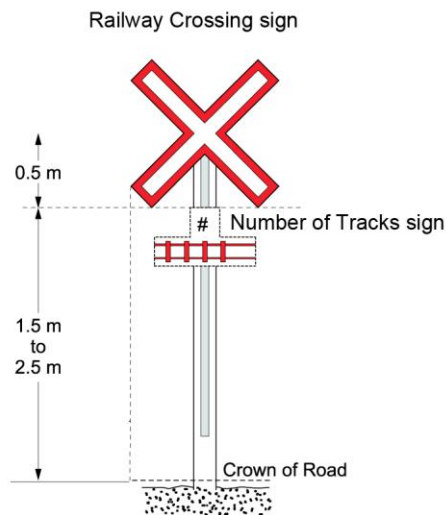

**Figure 4-3 – Railway Crossing Sign and Number of Tracks Sign on a Grade Crossing Warning Signal of Flashing Light Type**

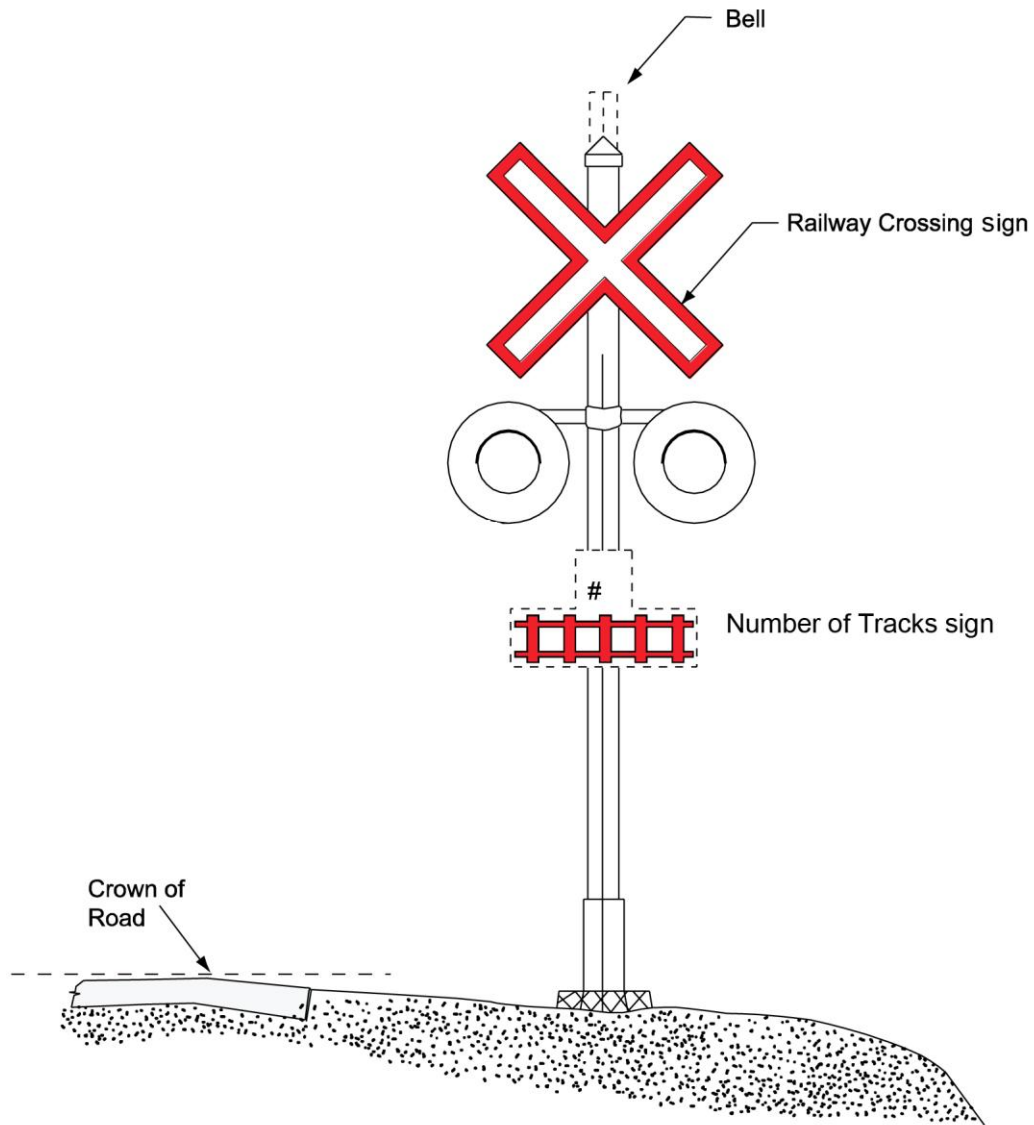



**Grade Crossings Standards, July 2014**

**Figure 4-4 – Railway Crossing Sign and Number of Tracks Sign where Gates at a Grade Crossing**

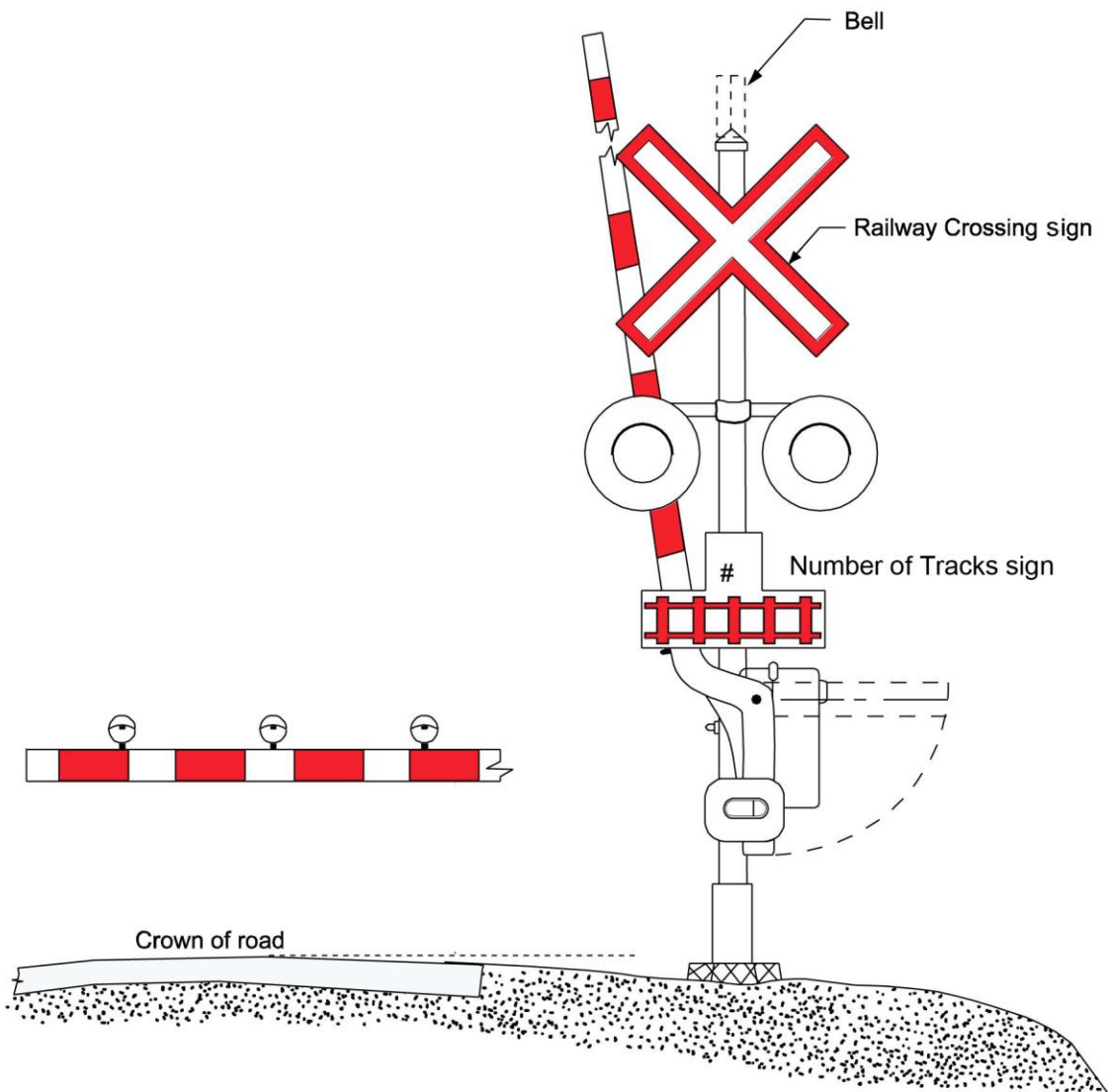

## PART C - NEW STANDARDS

### 5 CROSSING SURFACE

5.1 Crossing surface of a grade crossing, and a crossing surface of a sidewalk, path or trail must be as shown in Figure 5-1 and in accordance with Table 5-1, and must be smooth and continuous.

**Figure 5-1 – Grade Crossing Surface Dimensions**

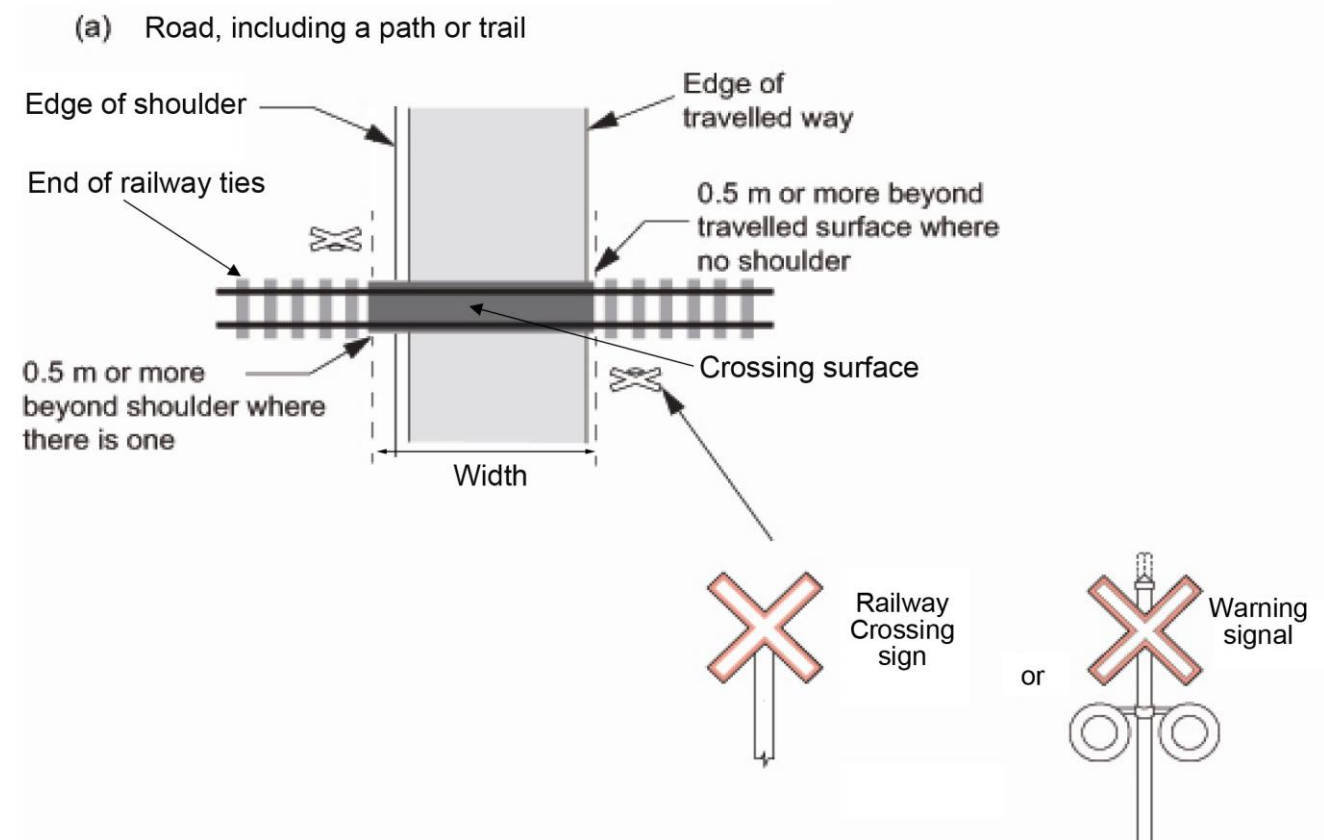

(b) Sidewalk, path, or trail along a road

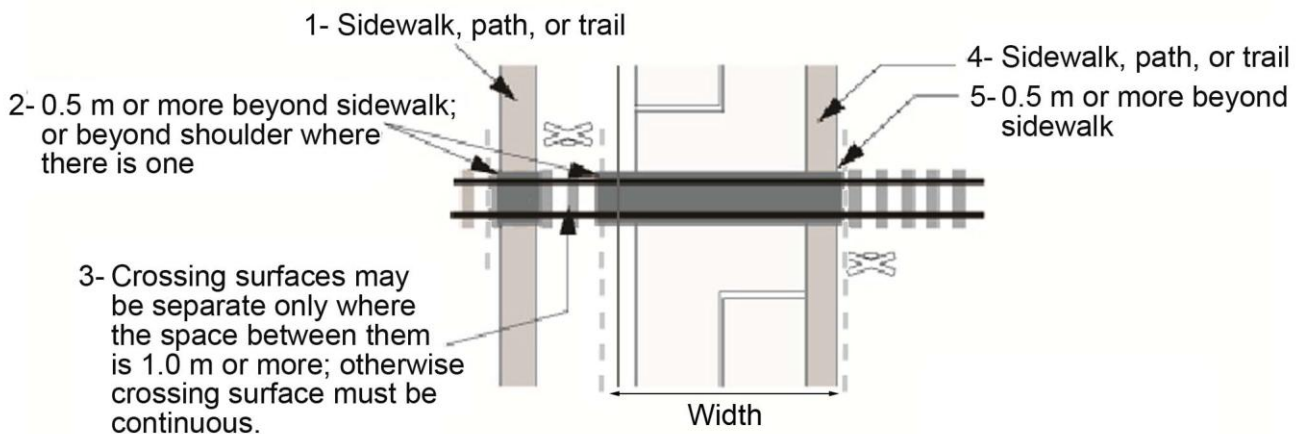

## Grade Crossings Standards, July 2014

**Table 5-1 – Grade Crossing Surface – Cross Section**

<b>a) Flangeway:</b>		
<b>Width</b>	<b>Minimum</b>	65 mm
	<b>Maximum for:</b>	
	Public sidewalks, paths or trails designated by the road authority for use by persons using assistive devices	75 mm
	All other grade crossings	120 mm
<b>Depth:</b>	<b>Minimum</b>	50 mm
	<b>Maximum for:</b>	
	Public sidewalks, paths and trails designated by the road authority for use by persons using assistive devices	75 mm
	All other grade crossings	No limit
<b>(b) Field side gap</b>		
A space is permitted on the outer side of the rail at rural locations, except for public sidewalks, paths or trails designated by the road authority for use by persons using assistive devices		
	Maximum width	120 mm
	Maximum depth	No limit
<b>(c) Elevation of the top of the rail with respect to the crossing surface</b>		
The top of the crossing surface must be installed as close as possible to the top of the rail within the wear limits below:		
<b>Wear limits:</b>		
Public sidewalk, path or trail designated by the road authority for use by persons using assistive devices		
	Maximum distance of the top of the rail above crossing surface	13 mm
	Maximum distance of the top of the rail below crossing surface	7 mm
All other public grade crossings; the maximum distance of the top of the rail above or below the crossing surface		25 mm
Private grade crossings; the maximum distance of the top of the rail above or below the crossing surface		50 mm

## Grade Crossings Standards, July 2014

### 6 ROAD GEOMETRY (GRADE CROSSINGS AND ROAD APPROACHES)

- 6.1 The horizontal and vertical alignment of the road approach and the crossing surface must be smooth and continuous.
- 6.2 The allowable difference between the road approach gradient and railway cross-slope, or the railway gradient and the road approach cross-slope, must be in accordance with Table 6-1 *Difference in Gradient*.
- 6.3 The maximum gradients for road approaches must not exceed the following:
- (a) ratio of 1:50 (2 per cent) within 8 m of the nearest rail and 1:20 (5 per cent) for 10 m beyond, at public grade crossings for vehicular use;
  - (b) ratio of 1:50 (2 per cent) within 8 m of the nearest rail and 1:10 (10 per cent) for 10 m beyond, at private grade crossings for vehicular use;
  - (c) ratio of 1:50 (2 per cent) within 5 m of the nearest rail at a sidewalk, path or trail ; and
  - (d) ratio of 1:100 (1 per cent) within 5 m of the nearest rail at a sidewalk, path or trail designated by the road authority for use by persons using assistive devices.
- 6.4 The width of the travelled way and shoulders at the crossing surface must not be less than the width of the travelled way and shoulders on the road approaches.
- 6.5 A grade crossing angle, measured from the tangent of the centreline of the road approach at the crossing surface, to the tangent of the centreline of the line of railway, shall, where the railway design speed is more than 25 km/h (15 mph) be:
- (a) not less than 70 and not greater than 110 degrees for grade crossings without a warning system; or
  - (b) not less than 30 and not greater than 150 degrees for grade crossings with a warning system.

## Grade Crossings Standards, July 2014

**Table 6-1 – Difference in Gradient**

Classification	Difference in Gradient (%)
RLU	2
RCU	1
RCD	1
RAU	0
RAD	0
RFD	-
ULU	3
UCU	2
UCD	2
UAU	0

*Legend						
Urban (U)	Rural (R)	Local (L)	Collector (C)	Arterial(A)	Expressway (E)	Freeway(F)
Divided (D)			Undivided (U)			

Source: *Geometric Design Guide for Canadian Roads*, published by the Transportation Association of Canada and dated September 1999

# Grade Crossings Standards, July 2014

## 7 SIGHTLINES

### 7.1 General

- 7.1.1 Sightlines are measured from a point 1.05 m above the road surface to a point 1.2 m above top of lowest rail.
- 7.1.2 For the purposes of section 28(b) of the GCR, refer to the Class of Track in the Table below:

<b>Column 1</b>	<b>Column 2</b>	<b>Column 3</b>
<b>Class of Track</b>	<b>The maximum allowable operating speed for freight trains is -</b>	<b>The maximum allowable operating speed for passenger trains is -</b>
Class 1 track	17 km/h (10 mph)	25 km/h (15 mph)
Class 2 track	41 km/h (25 mph)	49 km/h (30 mph)
Class 3 track	65 km/h (40 mph)	97 km/h (60 mph)
Class 4 track	97 km/h (60 mph)	129 km/h (80 mph)
Class 5 track	129 km/h (80 mph)	153 km/h (95 mph)

### 7.2 Determination of sightlines

In Figure 7-1,

- (a) SSD is the stopping sight distance and is calculated using the following formula:

$$SSD = 0.278 \times 2.5 \times V + d$$

d = braking distance (m)

V = initial speed (km/h)

- (b)  $D_{SSD}$  is the minimum distance along the line of railway that a crossing user must see approaching railway equipment from the stopping sight distance, and does not apply if the grade crossing is equipped with a Stop sign or warning system.

$D_{SSD}$  is equal to the distance required for the design vehicle at its road crossing design speed to go from the stopping sight distance completely past the clearance point on the other side of the grade crossing.

$$D_{SSD} = 0.278 V_T \times T_{SSD} \text{ (m)}$$

$$D_{SSD} = 1.47V_T \times T_{SSD} \text{ (ft.)}$$

Where,

$V_T$  = railway design speed in km/h or mph, and

$$T_{SSD} = [(SSD + cd + L)/0.278V] \text{ (s)}$$

Where,

V = road crossing design speed (km/h)

cd = grade crossing clearance distance (m)

L = length of the grade crossing design vehicle (m)

## Grade Crossings Standards, July 2014

- (c)  $D_{\text{Stopped}}$  is the minimum distance along the line of railway that a crossing user must be able to see approaching railway equipment from the stopped position at a grade crossing.

$D_{\text{Stopped}}$  is equal to the greater of the distances that railway equipment at the railway design speed will travel during

- (i) the Departure Time for the grade crossing design vehicle calculated in accordance with article 10.3.2, or
- (ii) the Departure Time for pedestrians, cyclists, and persons using assistive devices calculated in accordance with article 10.3.3.

$D_{\text{Stopped}}$  must be calculated by the following formula:

$$D_{\text{Stopped}} = 0.278 V_T \times T_{\text{Stopped}} \text{ (m)}$$

$$D_{\text{Stopped}} = 1.47 V_T \times T_{\text{Stopped}} \text{ (ft.)}$$

Where,

$V_T$  = railway design speed in km/h or mph

$T_{\text{Stopped}}$  = the Departure Times, calculated in accordance with article 10.3

## Grade Crossings Standards, July 2014

**Figure 7-1 – Minimum Sightlines – Grade Crossings**

- (a) Sightlines for Users Stopped at a Grade Crossing (applicable to all quadrants).

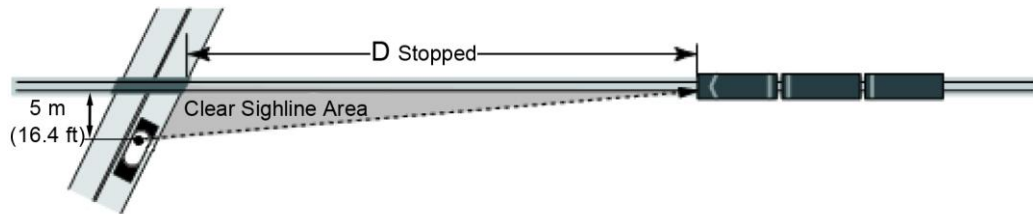

- (b) Sightlines for Users Approaching a Grade Crossing (applicable to all quadrants).

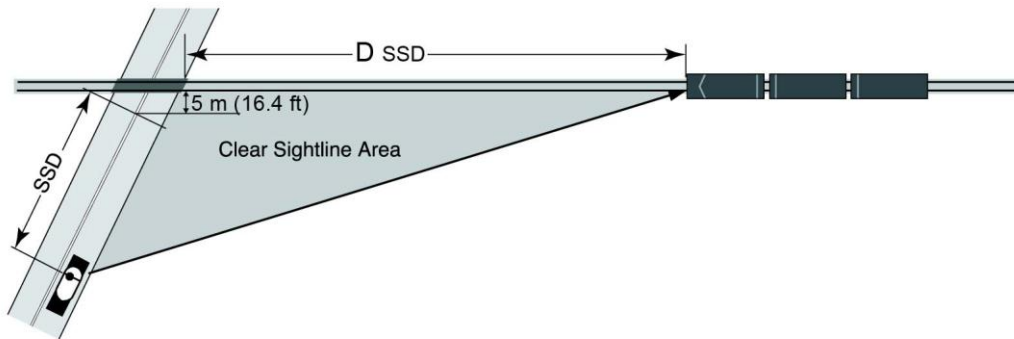



# Grade Crossings Standards, July 2014

## 8 SIGNS

### 8.1 Railway Crossing Sign and Number of Tracks Sign

#### All grade crossings:

- 8.1.1 A sign providing warning of a grade crossing (Railway Crossing sign) must be as shown in Figure 8-1(a) and must:
- have a retroreflective coating that covers the entire front surface of the sign;
  - have a 50 mm border on the front of each blade, with transparent red ink silk-screen processed over sheeting material;
- 8.1.2 A sign indicating the number of tracks at a grade crossing (Number of Tracks sign) must be as shown in Figure 8-1(b) and must:
- have a retroreflective coating that covers the entire front surface of the sign;
  - have a digit and symbol that is transparent red inked silk-screened processed; and
  - be installed on the supporting post of each railway crossing sign as shown in Figure 8-3(c)

#### Additional requirements for grade crossings without Warning Systems

- 8.1.3 A 100 mm retroreflective strip must be applied on the back of each blade of the Railway Crossing Sign, for the full length of each blade;
- 8.1.4 A 50 mm strip of silver white sheeting must be applied on the front and back of the supporting post, extending from no higher than 300 mm above the crown of the adjacent road surface to 70 mm above the centre of the Railway Crossing sign and must be as shown in Figure 8-2.
- 8.1.5 The railway crossing sign must be located:
- between 0.3 m and 2.0 m from the face of the curb, or the outer edge of the road shoulder or, where there is no curb or shoulder, 2.0 m to 4.5 m from the edge of the travelled way; and
  - must not be located closer than 3 m measured to the nearest rail, as shown in Figure 8-3(a) and 8-3(b).
- 8.1.6 A sidewalk, path or trail with a centreline that is more than 3.6 m (12 ft.) from a Railway Crossing sign supporting post beside a road approach for vehicle traffic must have separate Railway Crossing signs, as shown in Figure 8-3(a).
- 8.1.7 The supporting post, on which is installed the Railway Crossing sign and the Number of Tracks sign, must:
- Unless the Railway Crossing sign is installed on the mast of a warning system, the supporting posts must be of such construction that a 820 kg vehicle striking it at speeds 32 km/h or more, will not have a change in velocity greater than 4.57 m per second.

#### Retroreflective Material

- 8.1.8 Retroreflective material referred to in 8.1.1 to 8.1.4 must meet the specifications for Type IV material, white sheeting, as specified in sections 4.2.4 and 6.1.4 of ASTM D4956 (cited in Part A) when tested in accordance with the Test Methods for Type IV material specified in sections 7 and 9 of that Standard.

## Grade Crossings Standards, July 2014

- 8.1.9 The retroreflection coefficient of the retroreflective material referred to in 8.1.8 is to be maintained above 50 per cent of the value specified for Type IV material specified in article 6.1.4 of *ASTM D4956* (cited in Part A).

# Grade Crossings Standards, July 2014

## Figure 8-1 – Railway Crossing Sign and Number of Tracks Sign

(a) RAILWAY CROSSING SIGN

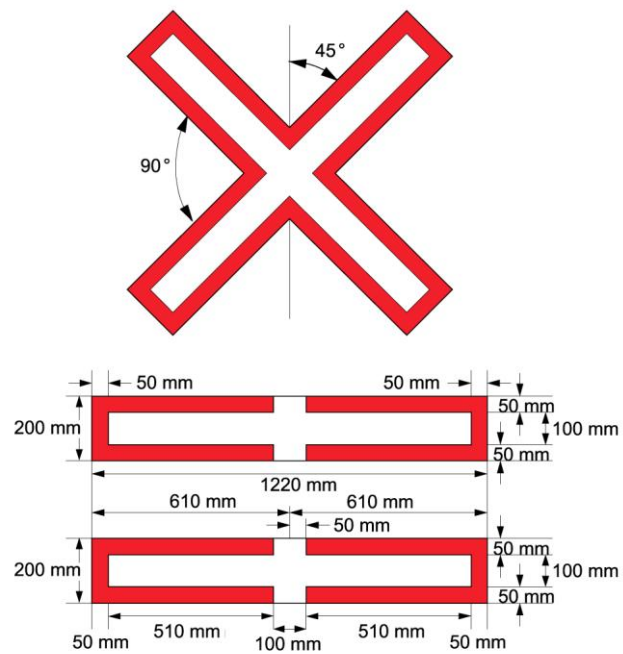

(b) NUMBER OF TRACKS SIGN

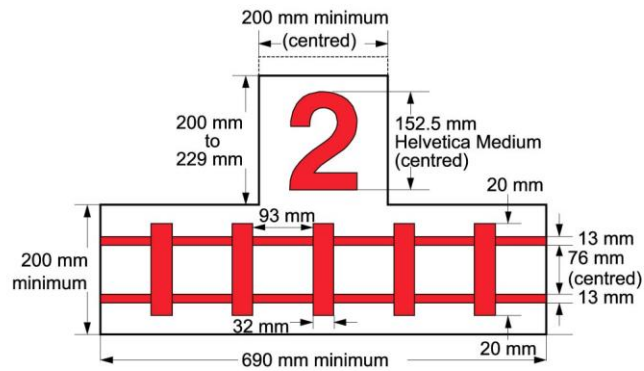

## Grade Crossings Standards, July 2014

**Figure 8-2 – Retroreflective Stripes on the Back of the Railway Crossing Sign and on the Sign Supporting Post (public grade crossings without a grade crossing warning system)**

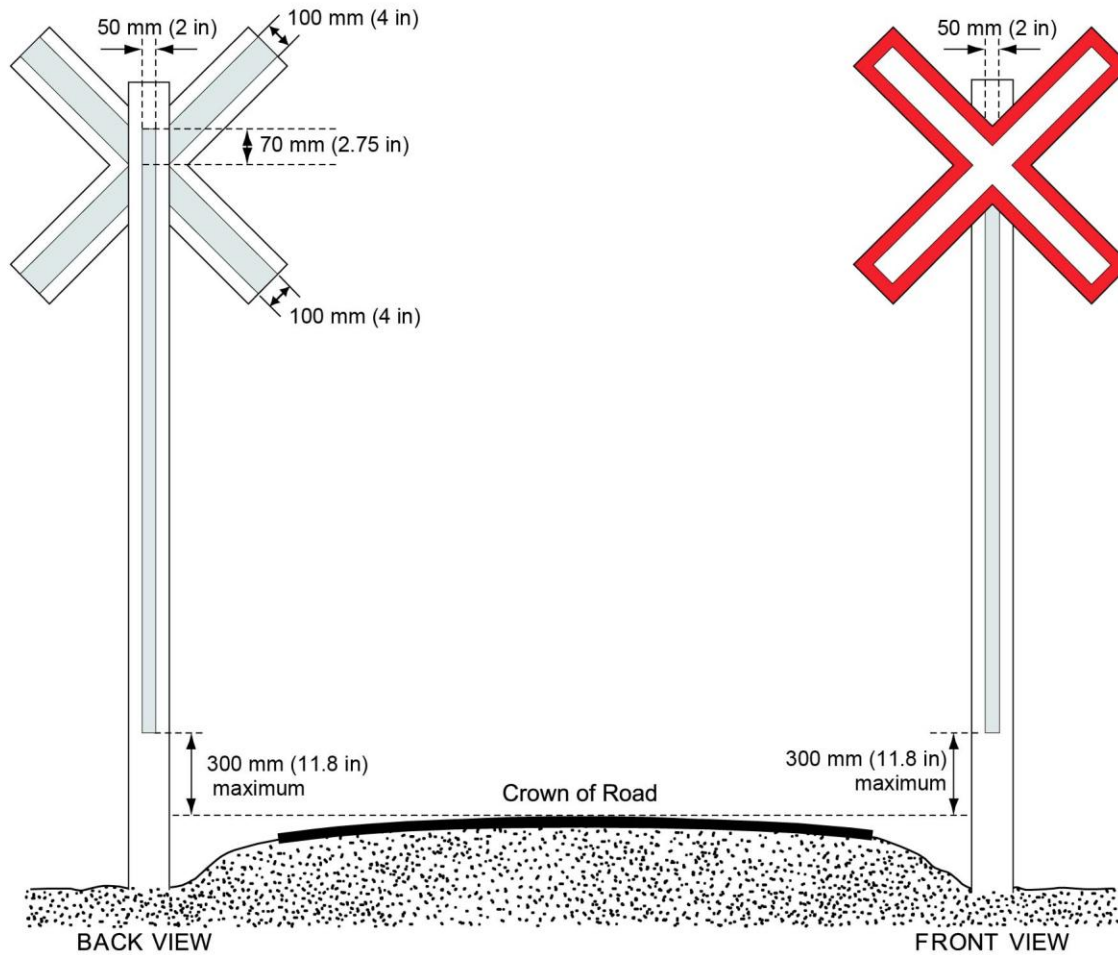

# Grade Crossings Standards, July 2014

**Figure 8-3 – Location of Railway Crossing Signs and Number of Tracks Signs (public grade crossings without warning systems)**

a)

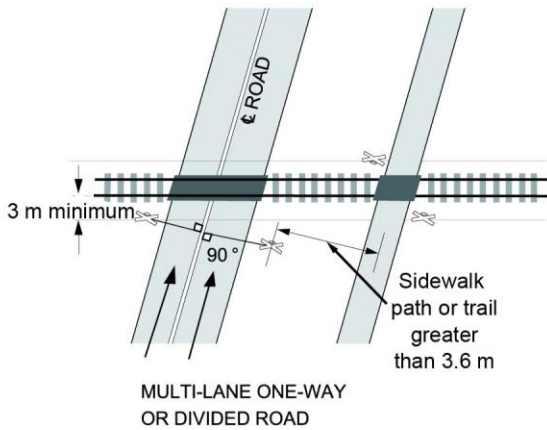

b)

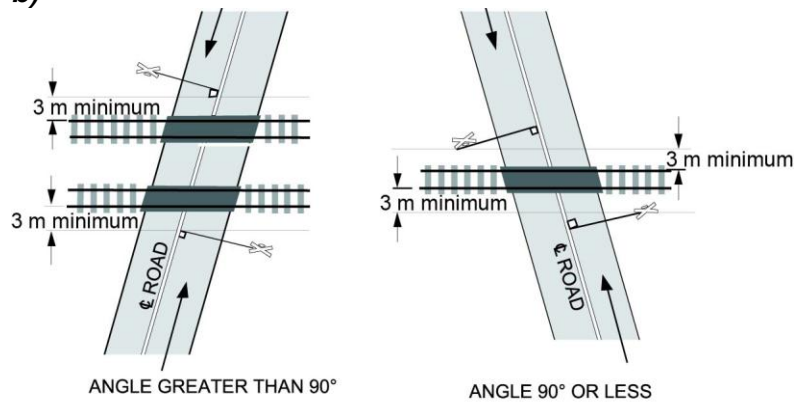

c)

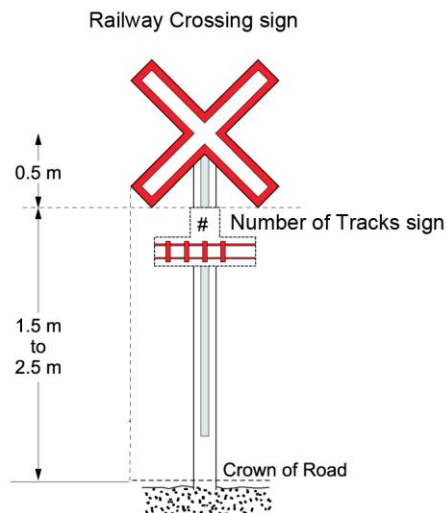

## Grade Crossings Standards, July 2014

### 8.2 Railway Crossing Ahead Sign and Advisory Speed Tab Sign

8.2.1 A sign providing advanced warning of a grade crossing (Railway Crossing Ahead sign) and a sign specifying a recommended speed (Advisory Speed Tab sign) must be as shown in articles A3.4.2 and A3.2.5 in the *Manual of Uniform Traffic Control Devices for Canada* (cited in Part A) and must meet the applicable standards set out in article A1.6 of that Manual, as the case may be.

### 8.3 Stop Ahead Sign

8.3.1 A Stop Ahead sign must be as shown in article A3.6.1 of the *Manual of Uniform Traffic Control Devices for Canada* (cited in Part A) and must meet the applicable standards set out in article A1.6 of that Manual.

### 8.4 Stop Sign

8.4.1 A Stop sign must be as shown in article A2.2.1 of the *Manual of Uniform Traffic Control Devices for Canada* (cited in Part A) and must meet the applicable standards set out in article A1.6 of that Manual. Where required by law, the word "Arrêt" will replace the word "Stop", or may be added to the Stop sign.

8.4.2 When a Stop sign is installed on the same post as a Railway Crossing sign, it must be installed as shown in Figure 8-4.

**Figure 8-4 – Stop Signs**

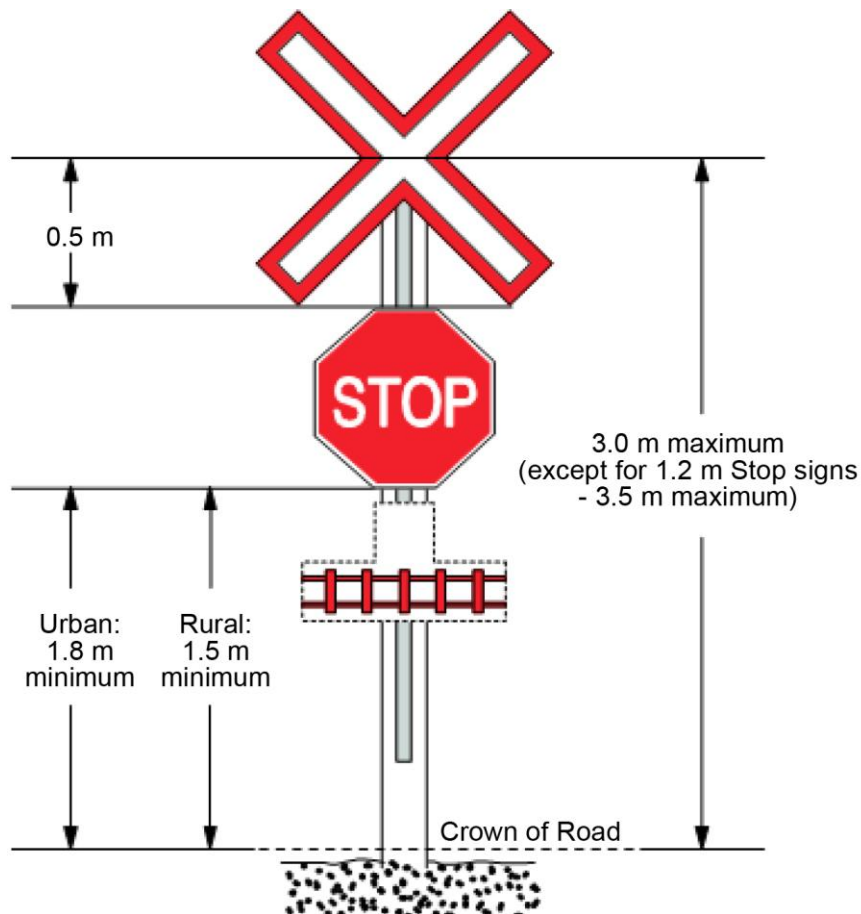

## **Grade Crossings Standards, July 2014**

### **8.5 Emergency Notification Sign**

- 8.5.1 An Emergency Notification sign that provides information on the location of the grade crossing and the railway company's emergency telephone number, must be installed
- a) parallel to the road, or
  - b) on each side of the grade crossing, facing traffic approaching the grade crossing.
- 8.5.2 the emergency notification sign must be clearly legible

## Grade Crossings Standards, July 2014

### 9 WARNING SYSTEMS SPECIFICATION

9.1 The specifications for a public grade crossing at which a warning system without gates is required are as follows:

- a) where the forecast cross-product is 2,000 or more;
- b) Where there is no sidewalk, path or trail and the railway design speed is more than 129 km/hr (80 mph);
- c) Where there is a sidewalk, path or trail and the railway design speed is more than 81 km/hr (50 mph); or
- d) where the railway design speed is more than 25 km/hr (15 mph) but less than the railway design speed referred to in b) or c), as the case may be, and
  - i. where there are two or more lines of railway where railway equipment may pass each other; or
  - ii. the distance as shown in Figure 9-1(a) between a Stop sign at an intersection and the nearest rail in the crossing surface is less than 30 m; or
  - iii. in the case of an intersection with a traffic signal, the distance between the stop line of the intersection and the nearest rail in the crossing surface, as shown in Figure 9-1(b), is less than 60 m, or where there is no stop line, the distance between the travelled way and the nearest rail in the crossing surface is less than 60 m.

9.2 The specifications for a public grade crossing at which a warning system with gates is required are as follows:

9.2.1 a warning system is required under article 9.1 and;

- (a) the forecast cross-product is 50,000 or more;
- (b) there are two or more lines of railway where railway equipment may pass each other;
- (c) the railway design speed is more than 81 km/hr (50 mph);
- (d) the distance as shown in Figure 9-1(a) between a Stop sign at an intersection and the nearest rail in the crossing surface is less than 30 m; or
- (e) in the case of an intersection with a traffic signal, the distance between the stop line of the intersection and the nearest rail in the crossing surface, as shown in Figure 9-1(b), is less than 60 m, or where there is no stop line, the distance between the travelled way and the nearest rail in the crossing surface is less than 60 m.

9.3 The specifications for a private grade crossing at which a warning system without gates is required are as follows:

9.3.1 where the forecast cross-product is 2,000 or more, or

9.3.2 where the railway design speed is more than 25 km/hr (15 mph), and;

- (a) the forecast cross-product is 100 or more and there are two or more lines of railway where railway equipment may pass each other;
- (b) the forecast cross-product is 100 or more and grade crossing does not includes a sidewalk, path or trail and the railway design speed is more than 129 km/hr (80 mph); or
- (c) the grade crossing includes a sidewalk, path or trail and the railway design speed is more than 81 km/hr (50 mph).



## Grade Crossings Standards, July 2014

9.4 The specifications for a private grade crossing at which a warning system with gates is required are as follows:

9.4.1 a warning system is required under article 9.3 and;

- (a) the forecast cross-product is 50,000 or more;
- (b) there are two or more lines of railway where railway equipment may pass each other; or
- (c) the railway design speed is more than 81 km/hr (50 mph).

9.5 The specifications for a grade crossing for a sidewalk, path or trail where a warning system is required are as follows:

- (a) the sidewalk, path or trail is outside the island circuit of an adjacent warning system, and
- (b) the railway design speed is more than 81 km/hr (50 mph).

9.6 The specifications for a grade crossing for a sidewalk, path or trail where a warning system with gates is required are as follows:

- (a) the sidewalk, path or trail is outside the island circuit of an adjacent warning system,
- (b) the railway design speed is more than 25 km/hr (15 mph), and
- (c) there are two or more lines of railway.

**Figure 9-1 – Proximity of Warning Systems to Stop Signs and Traffic Signals**

(a) Intersection with Stop Sign

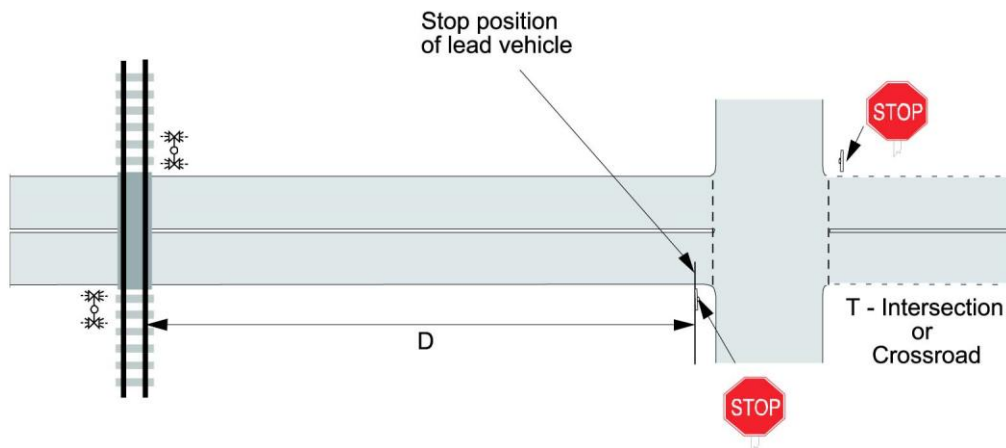

(b) Intersection with Traffic Signal

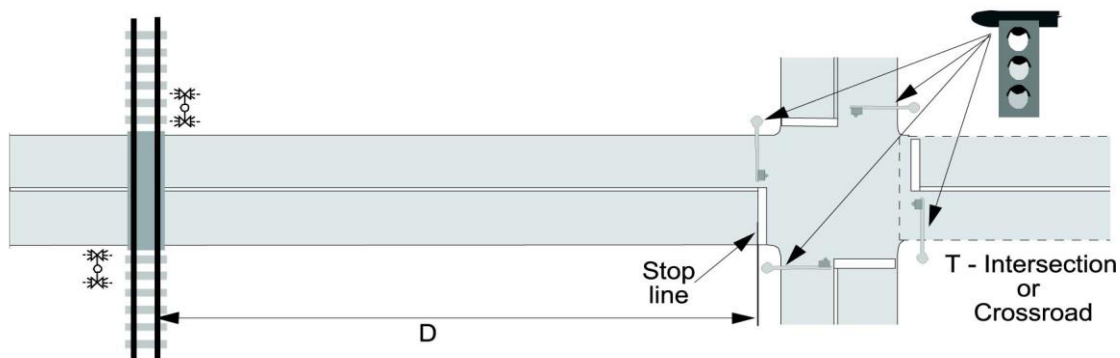

# Grade Crossings Standards, July 2014

## PART D – DESIGN CALCULATIONS

### 10 DESIGN CONSIDERATIONS

#### 10.1 Clearance Distance (cd)

- 10.1.1 *Clearance Distance* (cd) is defined as the distance, in metres, between the departure point in advance of the grade crossing, to the clearance point beyond the farthest rail, as shown in Figure 10-1.
- 10.1.2 The clearance point is the point 2.4 m beyond the outside edge of the farthest rail from the departure point measured perpendicular to the rail.

#### 10.2 Vehicle Travel Distance (S)

- 10.2.1 The total distance, in metres, the design vehicle must travel during acceleration to pass completely through the *Clearance Distance* (cd) is calculated using the following formula:

$$S = cd + L$$

**equation 10.2**

where,

cd = the *Clearance Distance*, in metres; and

L = the total length, in metres, of the design vehicle.

# Grade Crossings Standards, July 2014

Figure 10-1 – Clearance Distance (cd) for Grade Crossings

(a) For Grade Crossings with a Warning System or Railway Crossing Sign

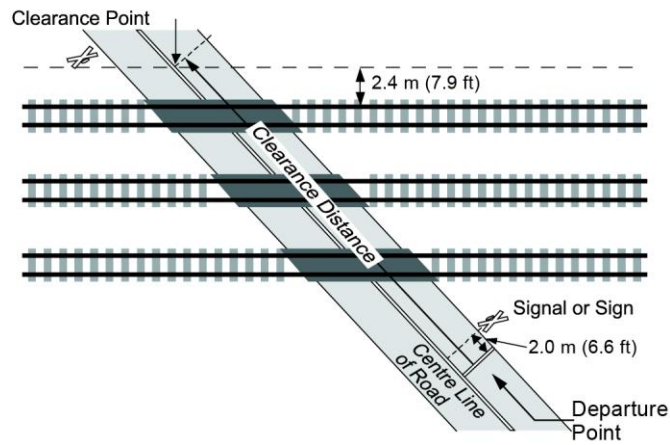

(b) For Grade Crossings without a Warning System or Railway Crossing Sign

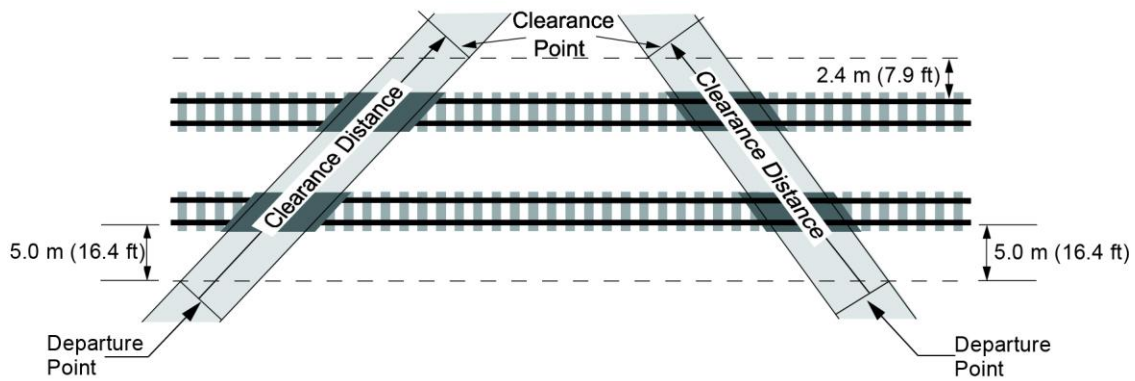

## Grade Crossings Standards, July 2014

### 10.3 Departure Time - General

- 10.3.1 The *Departure Time* is the greater of the time required for the design vehicle to pass completely through the *Clearance Distance* ( $cd$ ) from a stopped position ( $T_D$ ) or the time required for pedestrians, cyclists and persons using assistive devices to pass completely through the *Clearance Distance* ( $cd$ ) ( $T_P$ ).

Table 10-1 *Ratios of Acceleration Times on Grades* must be used to account for the effects of road gradient on the design vehicle for the grade crossing. The established ratio of acceleration time ( $G$ ) must be incorporated into the *Acceleration Time* ( $T$ ) by multiplying the acceleration time on level ground ( $t$ ) by the ratio of acceleration time ( $G$ ).

#### 10.3.2 Departure Time - Design Vehicle ( $T_D$ )

The total time, in seconds, the design vehicle must travel to pass completely through the *Clearance Distance* ( $cd$ ) is calculated using the following formula:

$$T_D = J + T \quad \text{equation 10.3a}$$

where,

$J$  = the perception-reaction time, in seconds, of the crossing user to look in both directions, shift gears, if necessary, and prepare to start (must use 2 seconds at minimum); and

$T$  = the time, in seconds, for the grade crossing design vehicle to travel through the *Vehicle Travel Distance* ( $S$ ) taking into account the actual road gradient at the grade crossing.

$T$  may be obtained through direct measurement or calculated using the following formula:

$$T = (t \times G) \quad \text{equation 10.3b}$$

where,

$t$  = the time, in seconds, required for the design vehicle to accelerate through the *Vehicle Travel Distance* ( $S$ ) on level ground established from Figure 10-2 *Assumed Acceleration Curves*; and

$G$  = the ratio of acceleration time established from Table 10-1 *Ratios of Acceleration Times on Grade* or may be obtained through direct measurement.

#### 10.3.3 Departure Time – Pedestrians, Cyclists and Persons Using Assistive Devices ( $T_P$ )

The total time, in seconds, that pedestrians, cyclists and persons using assistive devices must travel to pass completely through the *Clearance Distance* ( $cd$ ) is calculated using the following formula:

$$T_P = \frac{cd}{V_p} \quad \text{equation 10.3c}$$

where,

$cd$  = the *Clearance Distance*, in metres (Article 10.1); and

$V_p$  = the average travel speed, in metres per second (m/s), for pedestrians, cyclists, and persons using assistive devices (to a maximum value of 1.22 m/s).

## Grade Crossings Standards, July 2014

### 10.4 Gate Arm Clearance Time

10.4.1 *Gate Arm Clearance Time* is the greater of  $T_{G\ ssd}$  or  $T_{G\ stop}$  and represents the time, in seconds, it takes the design vehicle to travel from either the Stopping Sight Distance (SSD) position or the Stop position to the point past the gate arm.

**Gate Arm Clearance Time from the SSD position ( $T_{G\ ssd}$ )** is calculated as follows:

$$T_{G\ ssd} = \frac{cd_{G\ ssd}}{(0.27 \times V_{road})} \quad \text{equation 10.4a}$$

where,

$V_{road}$  = the road crossing design speed over the crossing in kilometres per hour (km/h);  
and

$$cd_{G\ ssd} = SSD + 2\ m + L$$

where,

SSD is the stopping sight distance, in metres, and is calculated using the following formula:

$$SSD = 0.278 \times 2.5 \times V + d$$

$d$  = braking distance (m)

$V$  = initial speed (km/h)

$L$  = the total length, in metres, of the design vehicle.

**Gate Arm Clearance Time from the Stop position ( $T_{G\ stop}$ )** is calculated as follows:

$$T_{G\ stop} = J + (t \times G) \quad \text{equation 10.4b}$$

where,

$J$  = 2 seconds, and is the perception-reaction time, in seconds, of the crossing user to look in both directions, shift gears, if necessary, and prepare to start; and

$G$  = the ratio of acceleration time established from Table 10-1 *Ratios of Acceleration Times on Grade* or may be obtained through direct measurement; and

$t$  = the time, in seconds, required for the design vehicle to accelerate through the Gate Arm Clearance Distance ( $cd_{G\ stop}$ ) on level ground established from Figure 10-2 *Assumed Acceleration Curves*;

where,

$$cd_{G\ stop} = 2\ m + L$$

where,

$L$  = the total length, in metres, of the design vehicle.

# Grade Crossings Standards, July 2014

## Figure 10-2 Assumed Acceleration Curves

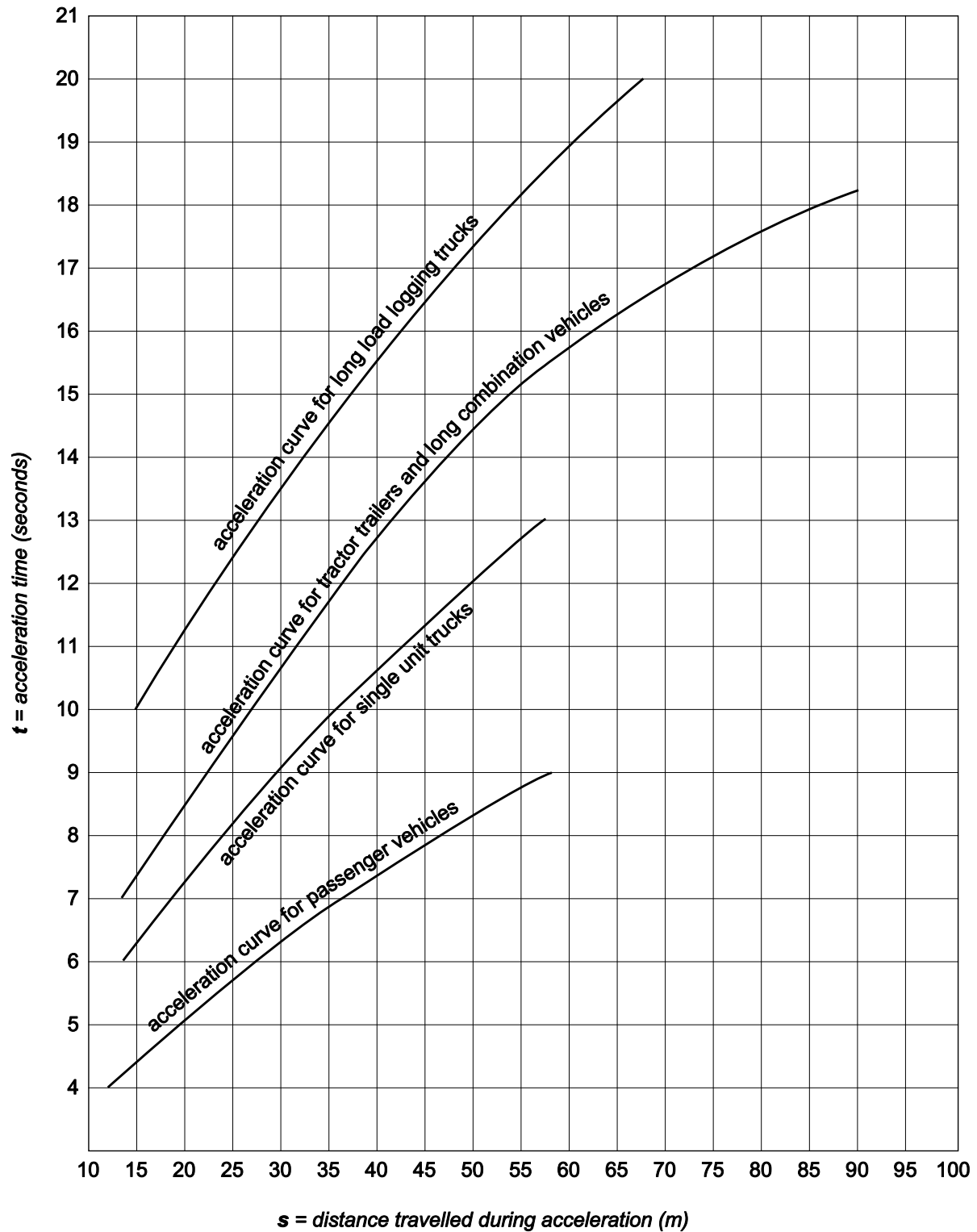

Source: *Geometric Design Guide for Canadian Roads*, published by the Transportation Association of Canada and dated September 1999

## Grade Crossings Standards, July 2014

**Table 10-1 Ratios of Acceleration Times on Grades**

<b>Design Vehicle</b>	<b>Road Grade (%)</b>				
	<b>-4</b>	<b>-2</b>	<b>0</b>	<b>+2</b>	<b>+4</b>
Passenger Car	0.7	0.9	1.0	1.1	1.3
Single Unit Truck & Buses	0.8	0.9	1.0	1.1	1.3
Tractor-Semitrailer	0.8	0.9	1.0	1.2	1.7

Source: *Geometric Design Guide for Canadian Roads*, published by the Transportation Association of Canada and dated September 1999

**Grade Crossings Standards, July 2014**

**Table 10-2 Road Design Specification for Road Approach**

<b>SPECIFICATIONS</b>		
<b>Column A</b>	<b>Column B</b>	<b>Column C</b>
Rural	Local	Divided
Urban	Collector	Not Divided
	Arterial	
	Expressway	
	Freeway	



## Grade Crossings Standards, July 2014

**Table 10-3 Characteristics of Rural Roads**

	<b>Rural Locals</b>	<b>Rural Collectors</b>	<b>Rural Arterials</b>	<b>Rural Freeways</b>
<b>Service function</b>	Traffic movement secondary consideration	Traffic and land access of equal importance	Traffic movement primary consideration	Optimum mobility
<b>Land service</b>	Land access primary consideration	Traffic movement and land access of equal importance	Land access secondary consideration	No access
<b>Traffic volume vehicles per day (typically)</b>	<1000 AADT	<5000 AADT	<1 2000 AADT	>8000AADT
<b>Flow characteristics</b>	Interrupted flow	Interrupted flow	Uninterrupted flow except at	free flow (grade separated) major intersections
<b>Design speed (km/h)</b>	50 – 110	60 - 110	80 – 130	100 – 300
<b>Average running speed (km/h) (free flow conditions)</b>	50 – 90	50 – 90	60 – 100	70 -110
<b>Vehicle type</b>	Predominantly passenger cars, light to medium trucks and occasional heavy trucks	All types, up to 30% trucks in the 3 t to 5 t range	All types, up to 20% trucks	All types, up to 20% heavy trucks
<b>Normal connections</b>	Locals collectors	Locals collectors arterials	Collectors arterials freeways	Arterials freeways

Source: *Geometric Design Guide for Canadian Roads*, published by the Transportation Association of Canada and dated September 1999

## Grade Crossings Standards, July 2014

**Table 10-4 Characteristics of Urban Roads**

	Public Lanes		Locals		Collectors		Arterials		Expressways	Freeways
	Residential	Commercial	Residential	Indust./Comm.	Residential	Indust./Comm.	Minor	Major		
Traffic service function	Traffic movement not a consideration		Traffic movement secondary consideration		Traffic movement and land access of equal importance		Traffic movement major consideration	Traffic movement primary consideration	Traffic movement primary consideration	Optimum mobility
Land service/access	Land access only function		Land access primary function		Traffic movement and access of equal importance		Some access control	Rigid access control	No access	no access
Traffic volume (veh/day) (typical)	<500	<1000	<1000	<3000	<8000	1000-12 000	5000 – 20 000	10 000 – 30 000	>10000	<20 000
Flow characteristics	Interrupted flow		Interrupted flow		Interrupted flow		Uninterrupted flow except at signals and crosswalks		Uninterrupted flow except at signals	Free-flow (grade separation)
Design speed (km/h)	30-40		30 – 50		50 - 80		40-60	50-90	80 – 110	80- 120
Average Running speeds (km/h) (off-peak)	20 - 30		20 - 40		30 - 70		40 - 60	50 -90	60 - 90	70 – 110
Vehicle type	Passenger and service vehicles	All types	Passenger and service vehicles	All types	Passenger and service vehicles	All types	All types	All types up to 20% trucks	All types up to 20% trucks	All types up to 20% trucks
Desirable connections	Public lanes, locals		Public lanes, locals, collectors		Locals, collectors, arterials		Collectors, arterials, expressways, freeway		Arterials, expressway, freeways	Arterials, expressways, freeways
Transit service	Public lanes, locals		Public lanes, locals, collectors		Locals, collectors, arterials		Express and local busses permitted		Express buses only	Express buses only
Accommodation of cyclists	No restriction or special facilities		No restriction or special facilities		No restriction or special facilities		Lanes widening or separate facilities desirable		prohibited	prohibited
Accommodation of pedestrians	Pedestrian permitted, no special facilities		Sidewalks normally on one or both sides	Sidewalks provided where required	Sidewalks provided both sides	Sidewalks provided where required	Sidewalks may be provided, separation for traffic lanes preferred		Pedestrian Prohibited	Pedestrian Prohibited
Parking (typically)	Some restrictions		No restrictions or restrictions one side only		Few restrictions other than peak hour		Peak hour restriction	Prohibited or peak hour restriction	prohibited	prohibited
Min. Intersection spacing <sup>1</sup> (m)	As needed		60		60		200	400	800	1600 (between interchanges)
Right-of-way width (m) (typically)	6 - 10		15 - 22		20 - 24		20 <sup>2</sup> - 45 <sup>3</sup>		>45 <sup>3</sup>	>60 <sup>3</sup>

Source: *Geometric Design Guide for Canadian Roads*, published by the Transportation Association of Canada and dated September 1999

# Grade Crossings Standards, July 2014

## 11 LOCATION OF GRADE CROSSINGS

11.1 A public grade crossing where the railway design speed is more than 25 km/h (15 mph) must be constructed so that no part of the travelled way of an intersecting road or entranceway (other than a railway service road), is closer than 30 m (D) to the nearest rail of the grade crossing (see Figure 11-1).

**Figure 11-1 – Restrictions on the Proximity of Intersections and Entranceways to Public Grade Crossings**

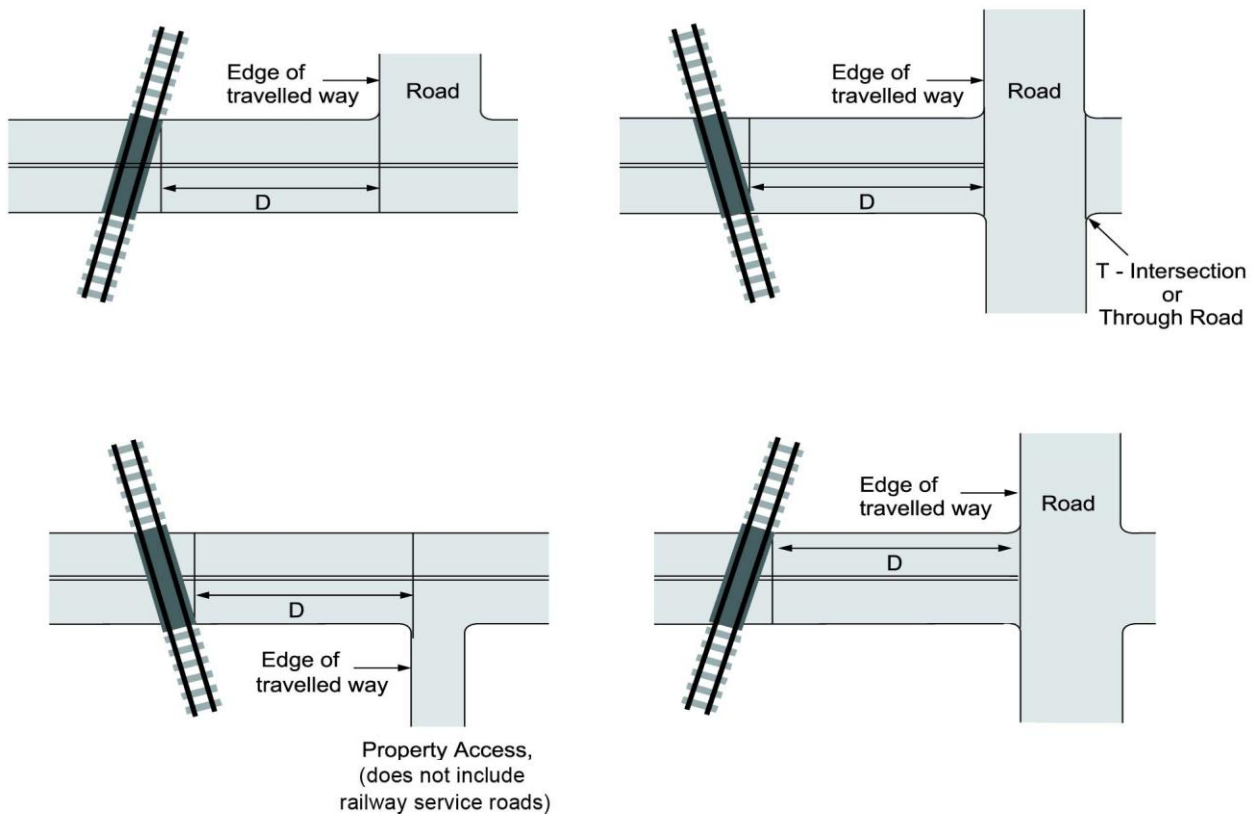

# PART E – WARNING SYSTEM DESIGN

## 12 WARNING SYSTEM OPERATION - GENERAL

- 12.0 Except as otherwise specified in articles 12 to 16 and Appendix B of these Standards or in the *Grade Crossings Regulations*, warning systems must be in accordance with the requirements and recommended practices of Part 3 of the *AREMA Communications and Signals Manual* (cited in Part A).
- 12.01 For the purposes of these Standards, the following interpretations and adjustments apply with respect to AREMA:
- (a) Any guidelines, recommendations, and similar matters are to be considered mandatory;
  - (b) Any references to “should” are to be read as “must”;
  - (c) The term “highway-rail grade crossing warning system” is to be read as “warning system”;
  - (d) The term “railroad” and the phrase “operators of the passenger or commuter rail system” is to be read as “railway company”;
  - (e) The term “lights” is to be read as “light units”;
  - (f) The term “train” is to be read as “railway equipment”;
  - (g) The term “roadway” and “roadway approach” is to be read as “road approach”;
  - (h) All references to the “MUTCD” are to be disregarded;
  - (i) All “Purpose” articles, paragraph 2 of article 3.1.16 G.1.(b)(ii) and article 3.2.35 K.5. are to be disregarded;
  - (j) The following are to be disregarded:
    - (i) all references to and requirements related to the “Diagnostic Team”;
    - (ii) all references to and requirements related to the “highway agency” or “highway agency or authority with jurisdiction”;
    - (iii) all references to and requirements related to the “agency” or “public agency”;
    - (iv) all references to and requirements related to “manufacturers” except where the requirement is to do something in accordance with the manufacturer’s instructions;
    - (v) all references to “unless otherwise specified” or “other considerations”, all references to approvals or orders, and any other reference to the exercise of discretion;
    - (vi) all purchase order requirements;
    - (vii) all requirements to create or keep records;
    - (viii) all requirements for a diagnostic review, an engineering study, a study of train operations, a risk analysis, a safety analysis, and all requirements to provide special instructions, operating rules, orders, or operational procedures.
- 12.1 Signal assemblies must be as shown in Figure 12-1, and gate assemblies must be as shown in Figure 12-2 and the cantilever assembly’s clearance must be as shown in Figure 12-3, and must meet the following specifications:
- (a) The minimum clearance distance from the face of a curb to the clearance line must be 625 mm (2 ft);

## Grade Crossings Standards, July 2014

- (b) Where there is no curb, the minimum clearance distance must be 1.875 m (6ft) from the edge of the travelled way to the clearance line and a minimum of 625 mm (2 ft) from the outer edge of the road approach shoulder to the clearance line, if there is a shoulder;
  - (c) The top of the warning signal foundation must be at a minimum of 100 mm (4 inches) above the surrounding ground. The slope of the surrounding ground away from the foundation toward the travelled way must not exceed the ratio of 4:1;
  - (d) The gate arm reflective materials shall have:
    - (i) stripes of 406 mm (16 inches), and must be affixed with white and red alternately and be aligned vertically;
    - (ii) Retroreflective material must meet the specifications for Type XI, white sheeting, in sections 4 and 6 of *ASTM D4956* (cited in Part A), when tested in accordance with the Test Methods for Type XI specified in sections 7 and 9 of that Standard; and
    - (iii) The retroreflection coefficient of the retroreflective material referred to in (ii) is to be maintained above 50 per cent of the value specified for Type XI, white sheeting, in sections 4 and 6 of *ASTM D4956* (cited in Part A).
  - (e) For grade crossings used by vehicles, gate arms must extend to no more than 1 m (3 ft) from the longitudinal axis of the road approach. Where gates are installed on each side of the same road approach, gate ends must extend to within 1 m (3 ft) of each other.
  - (f) Where gates are installed at sidewalks, paths or trails:
    - (i) Each gate arm must extend across the full width of the sidewalk, path or trail; and
    - (ii) in the case of a sidewalk, path or trail that is less than 3.5 m (11.5 ft.) wide, two lights are required on each gate arm located so that the lights are over the two points dividing the sidewalk, path or trail into thirds. The two gate arm lights must flash alternately.
  - (g) the height of the cantilever assembly clearance must be between 5.2 m (17 ft) and 6.0 m (20ft) above the crown of the road as shown in Figure 12-3.
- 12.2 In addition, warning systems must have monitoring devices that gather and retain the date and time of the following information for a minimum of 30 days;
- (a) Activation and deactivation of Interconnected devices;
  - (b) Gates have returned to or left the vertical position (Gate up Position);
  - (c) Gates have descended to a point 10 degrees from horizontal (Gate down Position);
  - (d) Activation of the warning system test switch
  - (e) Activation and deactivation of all track circuits used in the control of the warning system, including electronic track circuits;
  - (f) Activation of the warning system;
  - (g) Activation and deactivation of all devices used to control the warning systems at adjacent crossings; and
  - (h) Activation and deactivation of all devices used to activate the warning system from a location other than the crossing.
- 12.3 All control circuits that affect the safe operation of a warning system must operate in a manner that activates the warning system if there is a failure of a safety-critical component of that system.

## Grade Crossings Standards, July 2014

- 12.4 The electromagnetic, electronic, or electrical apparatus of a warning system must be operated and maintained in accordance with the limits to which the system is designed to operate.
- 12.5 Railway track circuits must:
- (a) detect railway equipment in any part of the track circuit;
  - (b) detect a shunt of 0.06 ohm resistance when the shunt is connected across the track rails of any part of the circuit;
  - (c) provide a set of fouling wires that consist of at least two discrete conductors and must ensure proper operation of the track circuit when the circuit is shunted. Single duplex wire with single plug is not permitted;
  - (d) in the case of a non-insulated rail joint within the limits of a track circuit, be bonded by means other than joint bars and the bonds must ensure electrical conductivity; and
  - (e) in the case of an insulated rail joint used to separate track circuits, prevent current from flowing between rails separated by the insulation.
- 12.6 Warning system battery back-up of 8 hours of continuous activation and 24 hours of normal railway operations must be provided.

# Grade Crossings Standards, July 2014

## Figure 12-1 – Warning Signal Assemblies

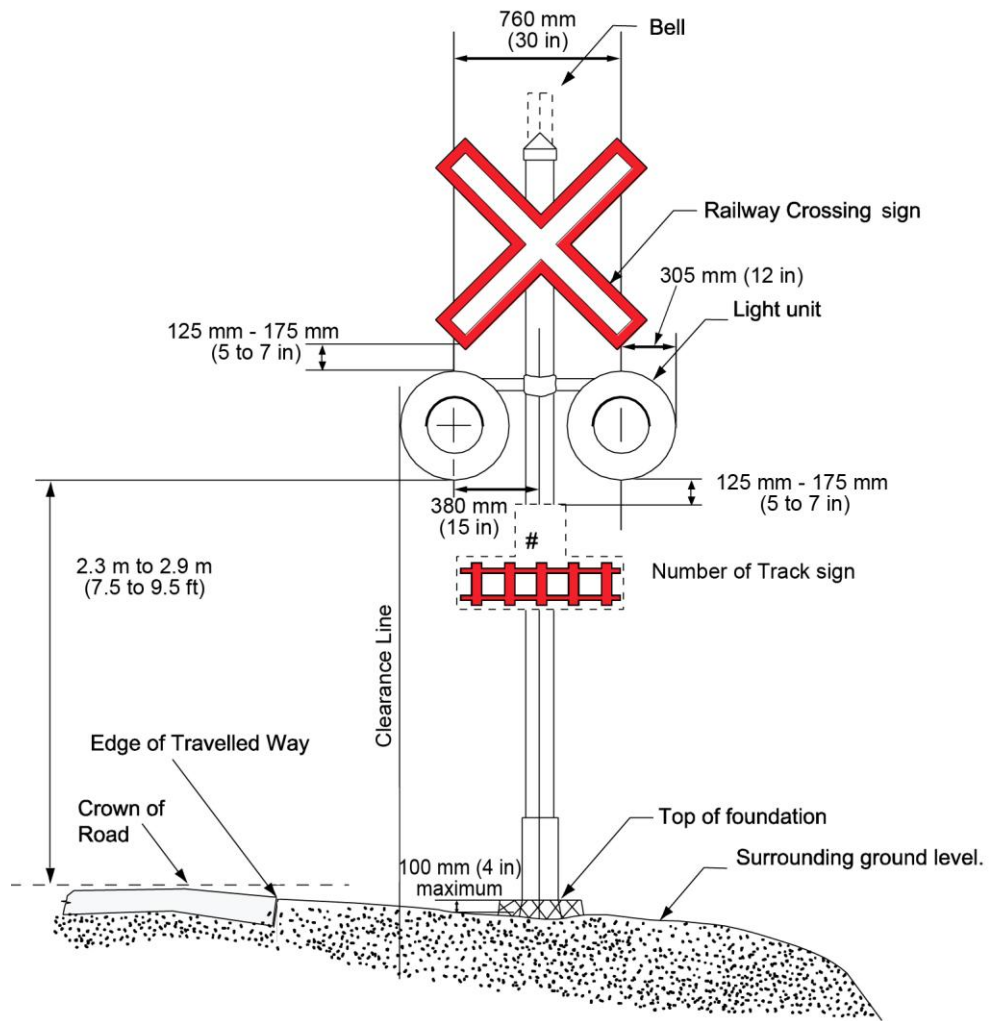

Figure 12-2 – Gates

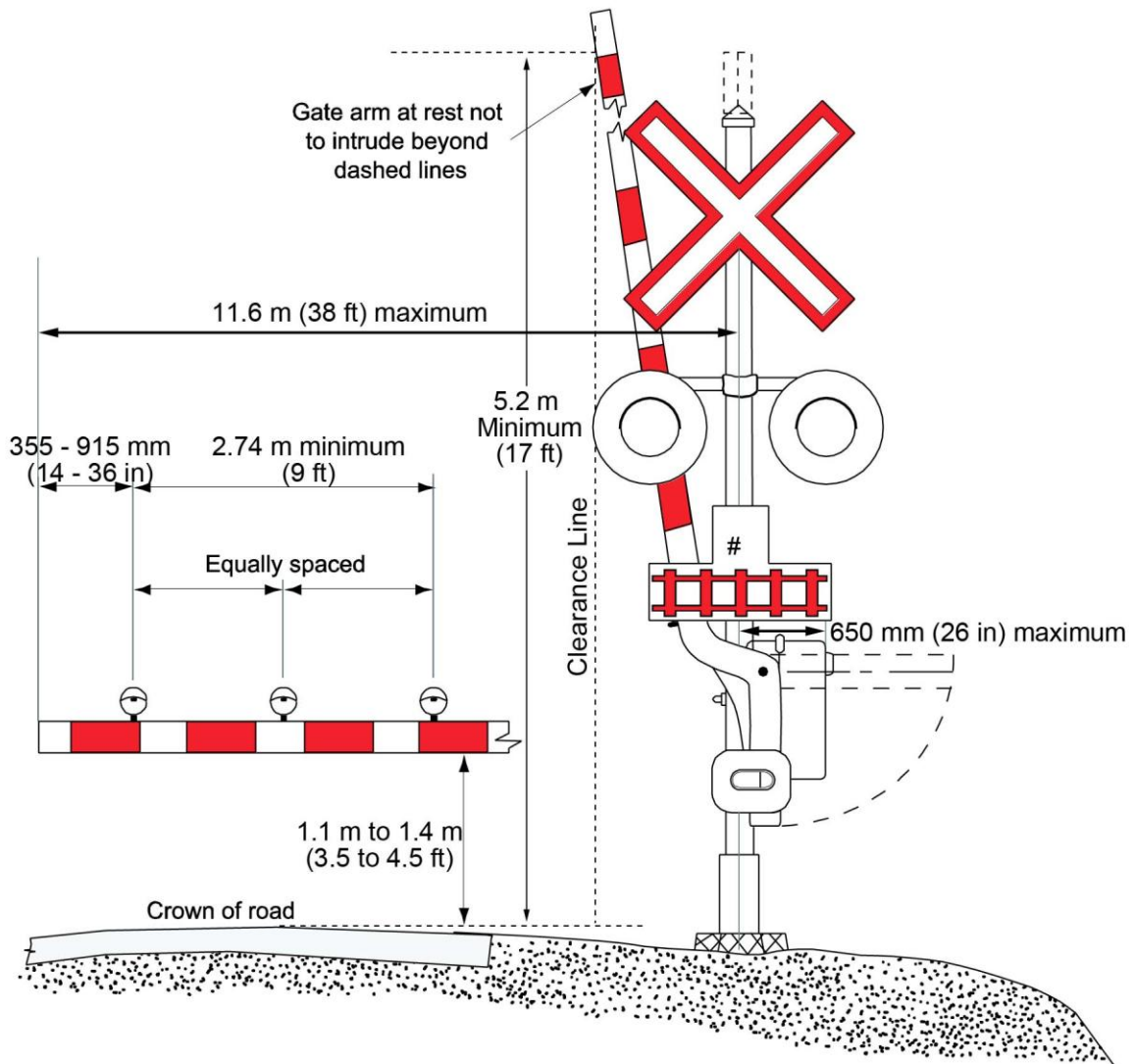
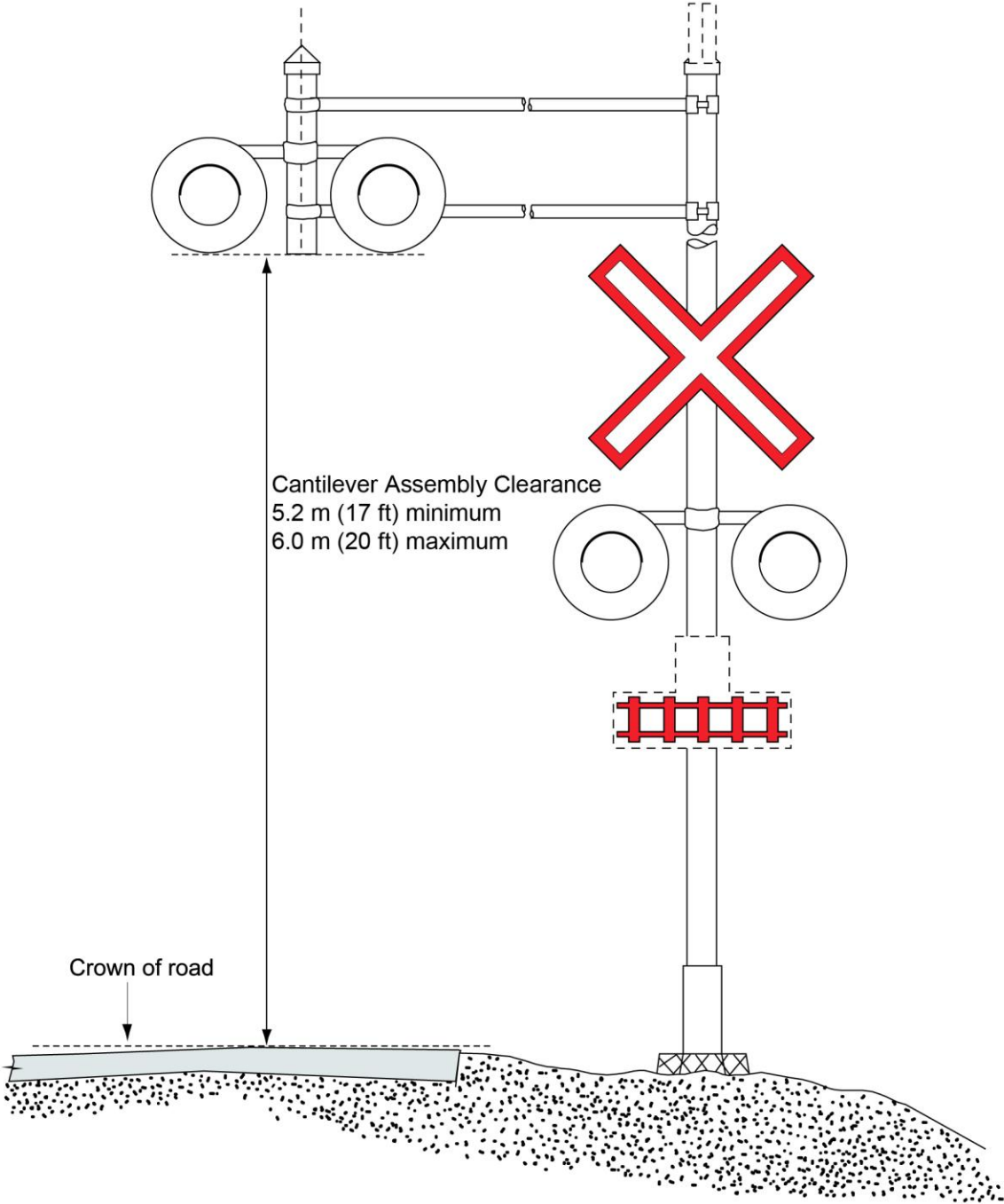



Figure 12-3 – Cantilevers



## Grade Crossings Standards, July 2014

### 13 NUMBER AND LOCATION OF LIGHT UNITS

- 13.0 Where incandescent lights are installed, the light unit voltage must be maintained between 90 and 110 per cent of the rated voltage under standby power conditions.
- 13.1 Light units must be installed in a warning system and located to ensure that the crossing user, on a road approach, or accessing a road approach:
- (a) is within the effective distribution pattern of luminous intensity of a set of light units within the distances specified for the front light units within SSD; and
  - (b) is able to see at least one set of front light units clearly.
- 13.2 Except for when the visibility of units is obstructed by railway equipment, light units must be provided in a warning system and located to ensure that a crossing user in the stopped position at the grade crossing;
- (a) is within the effective distribution pattern of luminous intensity of a set of back lights;
  - (b) so that at least one set of back lights is clearly visible to crossing users in each lane.

#### 13.3 Cantilevered Light Units

- 13.3.1 Except on a one-way road where a second warning signal is installed on the left side of the lane, a cantilevered light unit must be provided in a warning system if:
- (a) the distance between the centre of a warning signal mast and the edge of the lane of the road that is the farthest from the mast, measured perpendicular to the road, exceeds 7.7 m for DR, and 8.7 m for DL as shown in Figure 13-1;
  - (b) the front light units of the warning signal (i.e. those on the same side of the track as approaching traffic) are not clearly visible within the distance for the set of light units as specified in article 14.4.
- 13.3.2 Cantilevered light units must be installed for a warning system on a road that meets the specifications for an expressway as specified in Table 10-2.

#### 13.4 Light Units for a Sidewalk, Path or Trail

- 13.4.1 A sidewalk, path or trail with a centre line more than 3.6 m (12 feet) from the centre of a warning signal mast must have separate light units for each direction of travel, as shown in Figure 13-2(a).
- 13.4.2 Lights must be installed for persons travelling in the direction opposite to vehicle traffic where there is a sidewalk, path or trail along a one-way road as shown in Figure 13-2(b).

# Grade Crossings Standards, July 2014

## Figure 13-1 – Warning Signal Offsets Requiring Cantilevered Light Units

### (a) Two-Way Road

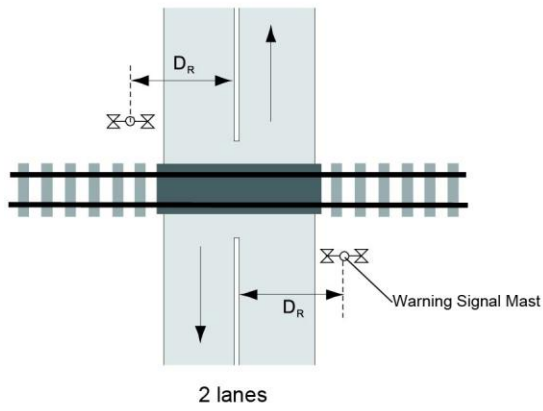

### (b) One-Way or Divided Road

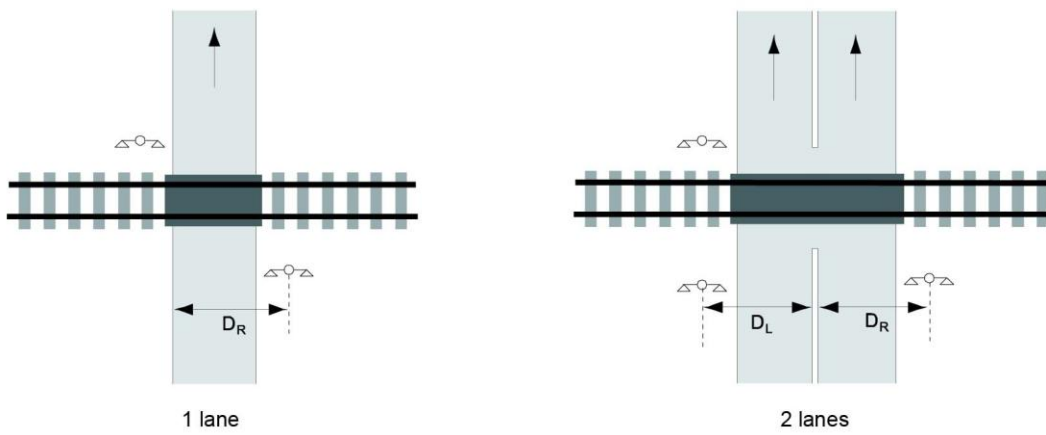
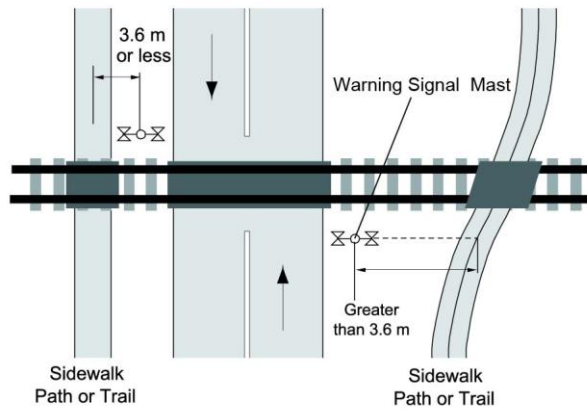
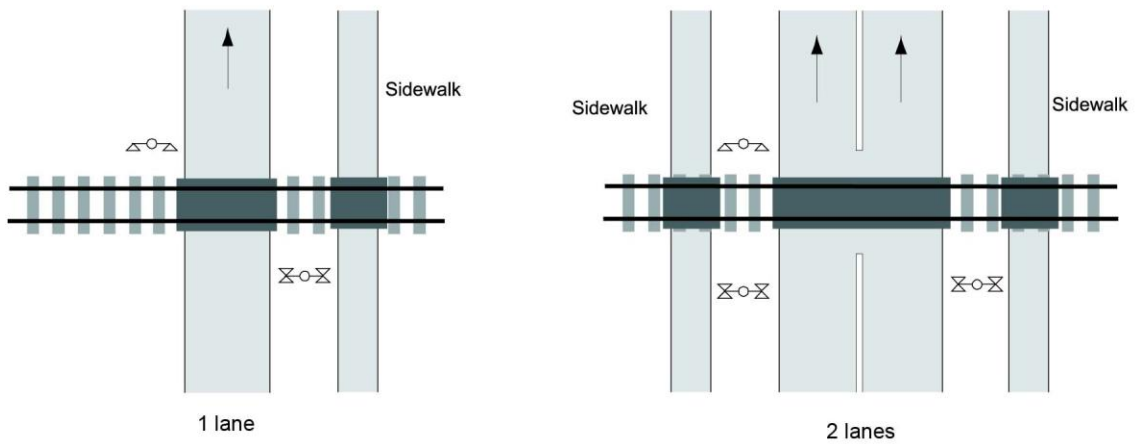

Figure 13-2 – Sidewalks, Paths and Trails

(a) Two Way



(b) One-Way



## **Grade Crossings Standards, July 2014**

### **14 LIGHT UNITS - ALIGNMENT**

#### **14.1 General – Light Units**

- 14.1.1 Light units must be 200 mm or 300 mm Light Emitting Diode (LED) signal module type and as specified in Appendix A.
- 14.1.2 Sets of light units of warning systems must flash alternately and uniformly at a rate of 45 to 65 flashes per minute.

#### **14.2 Alignment Height – Front and Back Lights for Vehicles**

- 14.2.1 Light units must be aligned so that the axes of the light units pass through a point 1.6 m above the road surface at stopping sight distance.

#### **14.3 Alignment Distance –Front Light Units for Vehicles**

- 14.3.1 Front light units must be aligned through the centre of the approaching traffic lane for which they are intended as follows:
  - (a) at a minimum, to the stopping sight distance; or
  - (b) at the point at which the light units are first visible, if this point is less than the distance specified in (a).

#### **14.4 Alignment – Intermediate Front Light Units for Vehicles**

- 14.4.1 Additional sets of light units must be aligned to cover any intermediate areas of the road approaches between the coverage provided by the front light units aligned as required in article 14.3 and the back lights aligned as required in article 14.5.
- 14.4.2 Additional sets of light units provided for a crossing user must be aligned through the point that is 1.6 m above the surface of the road, at the point at which the crossing user enters the road approach.

#### **14.5 Alignment – Back Light Units for Vehicles**

- 14.5.1 Back light units intended for motor vehicles approaching the grade crossing from a lane on the opposite side of the line of railway from the warning signal on which they are installed, must be aligned through the centre of that lane, 15 m in advance of the warning signal for that side of the line of railway.

#### **14.6 Alignment – Light Units installed exclusively for sidewalks, paths, or trails**

- 14.6.1 Light units installed exclusively for sidewalks, paths, or trails, must be aligned to be visible through a point 1.6 m above the centre of the sidewalk, path or trail and 30 m (100 ft) in advance of the nearest rail on both sides of the line of railway or the point at which the set of lights units first become visible if less than 30 m (100 ft).

### **15 BELLS AND GATES**

#### **15.1 Bells**

- 15.1.1 A bell is required for all warning systems, except for limited use warning systems referred to in Appendix B and for limited use warning systems with walk lights referred to in Appendix C.
- 15.1.2 Where there is only one sidewalk, path or trail along a road approach, the bell must be located on the signal mast adjacent to the sidewalk, path or trail.

## Grade Crossings Standards, July 2014

- 15.1.3 A bell is required on a signal mast adjacent to a sidewalk, path or trail if separated from any other signal mast with a bell by more than 30 m (100 ft).
- 15.1.4 All bells must continue to operate for the same duration as the light units.

### 15.2 Gates

- 15.2.1 The gate arm must be installed perpendicular to the longitudinal axis of the road approach.
- 15.2.2 The descent of the gate arm must take 10 to 15 seconds and its ascent must take 6 to 12 seconds.
- 15.2.3 The gate arm must begin its descent once the gate arm clearance time has elapsed, calculated in accordance with article 10.4.
- 15.2.4 For a grade crossing where railway equipment enters the grade crossing at more than 25 km/h (15 mph), the gate arm must rest in the horizontal position not less than 5 seconds before the arrival at the crossing surface of railway equipment.
  - 15.2.4.1 For a grade crossing where the railway equipment enters the grade crossing at 25 km/h (15 mph) or less, the gate arm must rest in the horizontal position when the railway equipment arrives at the crossing surface.
- 15.2.5 The gate arms must operate uniformly, smoothly, and complete all movements without rebound, and must be securely held when in the raised position.
- 15.2.6 If the gate arm strikes or fouls any object during its ascent or descent, it must readily stop and, on removal of an obstruction, assume the position corresponding with the control apparatus.

## 16 CIRCUITRY

### 16.1 Warning Time

- 16.1.1 The time during which the warning system must operate, before the arrival of railway equipment at the crossing surface, must be the greatest of:
  - (a) 20 seconds, unless the grade crossing clearance distance (Figure 10-1) is more than 11 m (35 ft), in which case, the 20 seconds must be increased by one second for each additional 3 m (10 ft), or fraction thereof;
  - (b) the Departure Time for the design vehicle (article 10.3.2);
  - (c) the Departure Time for pedestrians, cyclists, and persons using assistive devices (article 10.3.3);
  - (d) the gate arm clearance time, plus the time to complete the gate arm descent, plus 5 seconds;
  - (e) the minimum warning time required for traffic signal interconnection as referred to in article 19.3(a);
  - (f) the time for the design vehicle to travel from the stopping sight distance, and pass completely through the clearance distance.

### 16.2 Consistency of Warning Times

- 16.2.1 Operating control circuits must provide consistent warning times for railway equipment regularly operating over the grade crossing.
- 16.2.2 Where the maximum railway operating speed has been reduced, the approach warning times for railway equipment, regularly operating over the grade crossing, must not be more than 13 seconds longer than the warning time for the railway design speed.

## **Grade Crossings Standards, July 2014**

### **16.3 Cut-Outs**

- 16.3.1 Where railway equipment regularly stops, or railway equipment is left standing, within the activating limits of a warning system, the warning system must be equipped with a control feature to minimize the operation of the warning system.
- 16.3.2 A switch, when equipped with a switch circuit controller connected to the point and interconnected with the warning system circuitry, must cut out only when the switch point is within one-half inch of full reverse position.

### **16.4 Directional Stick Circuits**

- 16.4.1 Where a warning system is equipped with directional stick circuits, the circuit must:
- (a) include a stick release timer to activate the warning system after a preset time if there is failure of an approach circuit; or
  - (b) cause a train control signal system to restrict railway equipment speed to 25 km/h (15 mph) or less.

### **16.5 Identification**

- 16.5.1 Each wire in all housings, including switch circuit controllers and terminal or junction boxes, must be identified at each terminal and the identification must not interfere with moving parts of the warning system. Material used for identification purposes must be made of insulating material. This requirement does not apply to light units or wiring that is an integral part of solid state equipment.

## Grade Crossings Standards, July 2014

### 17 WARNING SYSTEMS AND TRAFFIC SIGNALS INSTALLED AT A GRADE CROSSING IN LIEU OF A WARNING SYSTEM - INSPECTION AND TESTING

- 17.1 Inspection and testing of warning systems must be done in accordance with article 3.3.1 and 3.1.15 of *AREMA Communications and Signals Manual* (cited in Part A).
- 17.2 Inspection and testing of traffic signals installed at a grade crossing in lieu of a warning system must be done in accordance with the road authority's procedures.

**Table 17-1 – Interpretation of Frequencies of Inspections and Tests for Warning Systems and Traffic Signals installed at a grade crossing in lieu of a warning system**

<b>COLUMN 1</b>	<b>COLUMN 2</b>	<b>COLUMN 3</b>
<b>DESIGNATED FREQUENCY</b>	<b>DEFINITION</b>	<b>MAXIMUM INTERVAL BETWEEN EACH INSPECTION OR TEST</b>
Weekly	Once every week (Sunday to Saturday)	10 clear days
Monthly	Once every calendar month	40 clear days
Quarterly	Once every 3 months (January to March, April to June, July to September, and October to December)	100 clear days
Twice annually	Once every 6 months (January to June and July to December)	200 clear days
Annually	Once every calendar year	13 months
Every 2 years	Once every 2 calendar years	26 months
Every 4 years	Once every 4 calendar years	52 months
Every 10 years	Once every 10 calendar years	130 months

**Table 17-2 – Required Frequencies of Inspections and Tests for Warning Systems and Traffic Signals installed at a grade crossing in lieu of a warning system**

<b>COLUMN 1</b>	<b>COLUMN 2</b>	<b>COLUMN 3</b>	<b>COLUMN 4</b>	<b>COLUMN 5</b>
<b>ITEM</b>	<b>Elements: Inspection and Testing requirements</b>	<b>Frequency for Warning Systems and Traffic Signals installed at a grade crossing in lieu of a warning system</b>	<b>Frequency for Limited Use Warning Systems</b>	<b>Frequency for Limited Use Warning Systems with Walk Light</b>
1	Warning Systems: for operation of lights, bell, gates, and power-off light.	Weekly or no more than 7 days before the operation of railway	N/A	N/A



## Grade Crossings Standards, July 2014

		equipment		
2	Light units: for misalignment, physical damage and conspicuity.	Monthly	Quarterly	Quarterly
3	Standby power: for operating bank voltage	Monthly	Quarterly	Quarterly
4	Light units, and gates: for damage, cleanliness, and visibility	Monthly	Quarterly	N/A
5	Bell: for operation	Monthly	N/A	N/A
6	Gate arm: for operation	Monthly	N/A	N/A
7	Surge protection: for condition	Monthly	Quarterly	Quarterly
8	Circuits: for grounds	Monthly	Quarterly	Quarterly
9	Battery: for isolation faults	Monthly	Quarterly	Quarterly
10	Batteries: for voltage, current, electrolyte level, and plate deterioration where plates are visible	Monthly	Quarterly	Quarterly
11	Interconnection components: for energization of circuits as intended.	Monthly	N/A	N/A
12	Switch circuit controller: for adjustment	Quarterly	Quarterly	Quarterly
13	Batteries: for degree of exhaustion, voltage and current	Quarterly	Quarterly	Quarterly
14	Fouling circuits: for continuity	Quarterly	Quarterly	Quarterly
15	Direct Current relays: visual check of condition	Twice Annually	Twice Annually	Twice Annually
16	Bond wires, track connections, insulated joints, and other insulated track appliances: visual check of condition	Twice Annually	Twice Annually	Twice Annually
17	Cut-out circuits (any circuit that overrides the operation of a warning system) : for operation	Twice Annually	Twice Annually	Twice Annually
18	Gate mechanism and circuit controller: visual inspection of condition	Twice Annually	N/A	N/A
19	Control circuits operation of traffic signals installed at a grade crossing in lieu of a warning system	Twice Annually	N/A	N/A
20	Light units: for proper alignment, focus, and visibility.	Annually	Annually	Annually
21	Light Unit: for voltage	Annually	Annually	Annually
22	Track circuits: for proper functioning	Annually	Annually	Annually
23	Flash controller: for flash rate	Annually	Annually	Annually
24	Battery: load test	Annually	Annually	Annually

## Grade Crossings Standards, July 2014

<b>25</b>	Warning time: for required time	Annually	Annually	Annually
<b>26</b>	Electronic railway equipment detection devices, including processor-based systems: for programming and function ability.	Annually	Annually	Annually
<b>27</b>	Timing relays and timing devices: for required time	Annually	Annually	Annually
<b>28</b>	Cable and wire entrances: for condition	Annually	Annually	Annually
<b>29</b>	Switch circuit controller centering device: for condition	Annually	Annually	Annually
<b>30</b>	Interconnection operation between of warning systems and traffic control devices	Annually	N/A	N/A
<b>31</b>	Pole line and attachments: for condition	Every Two Years	Every Two Years	Every Two Years
<b>32</b>	Gate mechanism: for electrical values, mechanical clearances and torque	Every Four Years	Every Four Years	Every Four Years
<b>33</b>	DC Polar, AC Vane, and Mechanical Timer relays: for electrical values and operating characteristics	Every Two Years	Every Two Years	Every Two Years
<b>34</b>	Relays that affect proper functioning of a warning system (except for DC polar, AC Vane and Mechanical Timer): for electrical values and operation	Every Four Years	Every Four Years	Every Four Years
<b>35</b>	Ground: for resistance value	Every Ten Years	Every Ten Years	Every Ten Years
<b>36</b>	Wire and cable insulation: for resistance	Every Ten Years	N/A	N/A

## PART F – INTERCONNECTED DEVICES

### 18 PREPARE TO STOP AT RAILWAY CROSSING SIGN

- 18.1 The Prepare to Stop at Railway Crossing sign must be as shown in A3.6.6 of the *Manual of Uniform Traffic Control Devices for Canada* (cited in Part A), must meet the applicable specifications in article A1.6 of that Manual, and must operate:
- (a) in advance of the activation of the light units of the warning system; and
  - (b) during the time of the operation of the light units of the warning system.
- 18.2 The advance activation time must be the greater of the time it takes a vehicle travelling at the road crossing design speed to pass a deactivated Prepare to Stop at Railway Crossing sign and the vehicle to:
- (a) clear the grade crossing before the arrival of railway equipment at the crossing surface where there is a warning system without gates; or
  - (b) clear the grade crossing before the gate arms start to descend where there is a warning system with gates.
- 18.3 Where a Prepare to Stop at Railway Crossing sign is installed, 4 hours continuous battery back-up power must be provided for the Prepare to Stop at Railway Crossing signs.

### 19 INTERCONNECTION OF TRAFFIC SIGNALS WITH WARNING SYSTEMS

- 19.1 Interconnection is to be provided at grade crossings where the railway design speed is 25 km/h (15 mph) or more and where there is less than 30 m between the nearest rail of a grade crossing and the travelled way of an intersection with traffic signals.
- 19.2 Except as otherwise specified in these standards or in the *Grade Crossings Regulations*, the design and operation of the interconnection of traffic signals with a warning system, at a grade crossing that corresponds to the specifications of 19.1, must be in accordance with Part 3.1.10 of the *AREMA Communications and Signals Manual* (cited in Part A).
- 19.3 The interconnection of traffic signals with a warning system must:
- (a) provide sufficient time for vehicles to clear the grade crossing before the arrival of railway equipment at the crossing surface.
  - (b) prevent movement of road traffic from the intersection towards the grade crossing.
- 19.4 Where traffic signals are interconnected by warning systems, 4 hours continuous battery back-up must be provided for the traffic signals.

## Grade Crossings Standards, July 2014

### 20 INTERCONNECTED DEVICES - INSPECTION AND TESTING

**Table 20-1 – Required Frequencies of Inspections and Tests for Prepare to Stop at Railway Crossing Signs or an Interconnected Traffic Signal**

<b>COLUMN 1</b>	<b>COLUMN 2</b>	<b>COLUMN 3</b>
<b><i>ITEM</i></b>	<b><i>Elements and Inspection and Testing requirements</i></b>	<b><i>Frequency</i></b>
1	Prepare to Stop at Railway Crossing sign: for visibility of light units	Annually
2	Traffic Signals installed at a grade crossing in lieu of a warning system: for cleanliness, visibility of signal heads, and physical damage	Annually
3	Traffic signal interconnection activation and operation with warning systems	Annually
4	Prepare to Stop at Railway Crossing Sign activation and operation	Annually

## APPENDIX A – LIGHT EMITTING DIODE (LED) SIGNAL MODULES

### Standards for LED Signal Modules in Warning Systems

#### 1 DEFINITIONS

**Candela (cd)** – SI unit of luminous intensity. The candela is the luminous intensity, in a given direction, of a source that emits monochromatic radiation of frequency 540 nm and that has a radiant intensity in that direction of 1/683 W per steradian (1 cd = 1 lm/sr).

**Lumen (lm)** – SI unit of luminous flux. Luminous flux emitted in unit solid angle [steradian (sr)] by a uniform point source having a luminous intensity of 1 candela (1 lm = 1 cd x 1 sr).

**Luminance  $L_v$  (in a given direction, at a given point on a real or imaginary surface)** – quantity defined by the formula:

$$L_v = \frac{d\Phi_v}{dA \cdot d\Omega \cdot \cos\theta}$$

where  $d\Phi_v$  is the luminous flux transmitted by an elementary beam passing through the given point and propagating in the solid angle  $d\Omega$  containing the given direction;  $dA$  is the area of a section of that beam containing the given point;  $\theta$  is the angle between the normal to that section and the direction of the beam (footlambert,  $\text{cd/m}^2$ ).

**Luminous Efficacy of Radiation (K)** – the luminous flux  $\Phi_v$  divided by the corresponding radiant flux  $\Phi_e$  ( $K = \Phi_v/\Phi_e$ ).

**Luminous Intensity ( $I_v$ ) (of a source in a given direction)** – the luminous flux  $d\Phi_v$  leaving the source and propagating in the element of solid angle  $d\Omega$  containing the given direction, divided by the element of solid angle ( $I_v = d\Phi_v / d\Omega$  candela).

**Luminous Flux ( $\Phi_v$ )** – quantity derived from radiant flux  $\Phi_e$  by evaluating the radiation according to its action upon the CIE standard photometric observer (lumen).

**Rated Voltage** – the nominal or design operating voltage of the LED signal module; the voltage at which rated watts, candelas, and life are determined.

**Rated Watts** – the average initial power (watts) consumed when the lamp is operated at rated voltage.

#### 2 PHOTOMETRIC REQUIREMENTS

##### 2.1 Luminous Intensity

When LED signal modules are in use at a warning system, they must meet the minimum luminous intensity values shown in Table A-1.

	0°	5° Left (L)/Right (R)	10° L/R	15° L/R	20° L/R	25° L/R	30° L/R
0°	400	375	250	150	75	40	15
5° Down (D)	350	325	250	150	75	40	15
10° D	130	125	110	85	60	35	15
15° D	45	40	35	30	25	20	15
20° D	15	15	15	15	15	15	10

## Grade Crossings Standards, July 2014

### 2.2 Chromaticity

A signal module must produce a uniform red light output as specified in article 4.2 of the *Vehicle Traffic Control Signal Heads – Light Emitting Diode Circular Supplement*, published by the *Institute of Transportation Engineers*, dated June 2005.

### 2.3 Uniformity

The ratio of the greatest and least luminance on the signal module must not be more than 5:1, when measured over average areas of 500 mm<sup>2</sup>.

### 2.4 Rise/Fall Time

The maximum rise time from zero intensity to full intensity, and the maximum fall time from full intensity to zero intensity, must be 75 ms.

## 3 PHYSICAL AND MECHANICAL REQUIREMENTS

### 3.1 LED Signal Module Design

- 3.1.1 The LED signal module must be designed to fit the grade crossing light unit housings, described in Part 3.2.35 of the *AREMA Communications and Signals Manual* (cited in Part A), without requiring modification of the mechanical, structural, or electrical components.
- 3.1.2 The LED signal module must be either 200 mm or 300 mm in size.
- 3.1.3 The LED signal module must have either a clear or a red lens.
- 3.1.4 Any gasket or similar sealing provisions must be made of a material as specified in Part 15.2.10 of the *AREMA Communications and Signals Manual* (cited in Part A).

### 3.2 Environmental Requirements

- 3.2.1 The LED signal module must operate over an ambient temperature range of -40°C (-40°F) to 70°C (158°F) in accordance with sections 1 to 3 of the "Method 1010.8 Temperature Cycling", dated June 18, 2004, of MIL-STD-883H, *Test Method Standard, Microcircuits*, published by the United States Department of Defence, dated February 26, 2010 and must satisfy the failure criteria set-out in article 3.3 of that standard, and any reference to end-point measurements and examinations are to be read as those provided by the supplier.
- 3.2.2 The LED signal module must be protected against dust and moisture intrusion in a Type 4 enclosure in a manner that meets the requirement of article 8.6.2 of the Canadian Standards Association standard CAN/CSA-C22.2 No. 94.2-07 entitled *Enclosures for Electrical Equipment, Environmental Considerations*, as amended from time to time, when tested in accordance with article 8.6.1 of that Standard.
- 3.2.3 The LED signal module must meet mechanical vibration and shock requirements as specified in Part 11.5.1 of the *AREMA Communications and Signals Manual* (cited in Part A).
- 3.2.4 The LED signal module lens must be UV stabilized.

### 3.3 Identification

- 3.3.1 The LED signal module must have a label containing the following information:
  - a) the LED colour;
  - b) the beam deflection classification;
  - c) the operating voltage;
  - d) the current consumption at operating voltage;

## **Grade Crossings Standards, July 2014**

- e) the module's serial number; and
  - f) the date of manufacture.
- 3.3.2 If the module or its components require orientation, they must be prominently and permanently marked with an indexing arrow.

### **4 ELECTRICAL REQUIREMENTS**

#### **4.1 Transient Voltage Protection**

LED signal module circuitry must include voltage surge protection as specified in Part 11.3.3 of *AREMA Communications and Signals Manual* (cited in Part A).

#### **4.2 LED Drive Circuitry**

LED signal module circuitry must operate as specified in Part 3.2.35 of the *AREMA Communications and Signals Manual* (cited in Part A).

#### **4.3 Dielectric and Electromagnetic Interference**

LED signal module circuitry must conform to dielectric and electromagnetic interference requirements for Class B equipment in Part 11.5.1 of *AREMA Communications and Signals Manual* (cited in Part A).

## **APPENDIX B - LIMITED USE WARNING SYSTEMS AND SIGNS**

### **1 Operating Requirements**

- 1.1 Battery backup for a minimum of 24 hours of normal railway operations must be provided.
- 1.2 Power monitor lights must be provided.

### **2 Warning System Requirements**

- 2.1 Limited Use Warning System must meet the specifications of articles 12 to 16 of the *Grade Crossings Standards (GCS)* except:
  - a) it does not require a gate;
  - b) height of the light unit may be different than that stated in the *AREMA Communications and Signals Manual* (cited in Part A) or the *GCS* (cited in Part A) as to improve conspicuity;
  - c) Signal mast may be located closer to the road approach than that stated in the *AREMA Communications and Signals Manual* (cited in Part A) or the *GCS* (cited in Part A) to improve conspicuity.
  - d) A bell is not required; and
  - e) Front and back lights must be provided on each warning signal assembly.

### **3 Signage Requirements**

- 3.1 An Emergency Notification sign must be installed at each location.
- 3.2 A sign indicating that the road is private must be posted near the entrance to the private road.



### APPENDIX C - LIMITED USE WARNING SYSTEM WITH WALK LIGHT

#### Operating Requirements

- 1.1 Battery backup of a minimum of 8 hours must be provided.
- 1.2 Power monitor lights must be provided.

#### Signal Requirements

- 1.3 A Limited Use Warning System with Walk Light must meet the specifications below:
  - a) must be installed on each side of the grade crossing and face a crossing user approaching the grade crossing;
  - b) must include a signal head that displays a signal indicating to a crossing user that it is safe to proceed when railway equipment is not approaching. This signal head must be extinguished when railway equipment is approaching;
  - c) The signal head must be as specified in sections 2 to 5, excluding the last paragraph of section 4.1.1, of the ITE *"Pedestrian Traffic Control Signal Indications - Part 2: Light Emitting Diode (LED) Pedestrian Traffic Signal Modules"* prepared by the Joint Industry and Traffic Engineering Council Committee, published by the Institute of Transportation Engineers, dated March 19, 2004, except for the following aspects:
    - i. 12VDC pedestrian module is to be used instead of a 120VAC input voltage;
    - ii. the operating voltage range must be 9 – 15VDC, and the light must shut off at 7.3VDC or less; and
    - iii. References to "LED Pedestrian Signal Module" or "Module" are to be read as "Walk Light".
  - d) The walk light indicating that it is safe to proceed must be extinguished a minimum of 20 seconds plus the clearance time before the arrival of railway equipment at the crossing surface.
  - e) The clearance time must be based on design vehicle and must be calculated in accordance with article 10 of the GCS (cited in Part A).

#### Signage and Post Requirements

- 1.4 Signage indicating how to use a Limited Use Warning Systems with Walk Light must be as shown in Figure C-2 and must:
  - a) be mounted on the mast under the walk light signal head as indicated in Figure C-1; and
  - b) have a silver background that is reflective with silk screened black or vinyl lettering. Where required by law, the word "Arrêt" may replace the word "Stop", or may be added to the Stop Sign.
- 1.5 A Stop sign must be as shown in article A2.2.1 of the *Manual of Uniform Traffic Control Devices for Canada* (cited in Part A) and must meet the applicable specifications A1.6 of that Manual. Where required by law, the word "Arrêt" will replace the word "Stop", or may be added to the Stop sign. The Stop sign must be mounted on the mast as shown in Figure C-1.
- 1.6 An Emergency Notification sign must be located at each Limited Use Warning System with Walk Light Assembly.

Figure C-1 – Limited Use Warning System with Walk Light Assembly

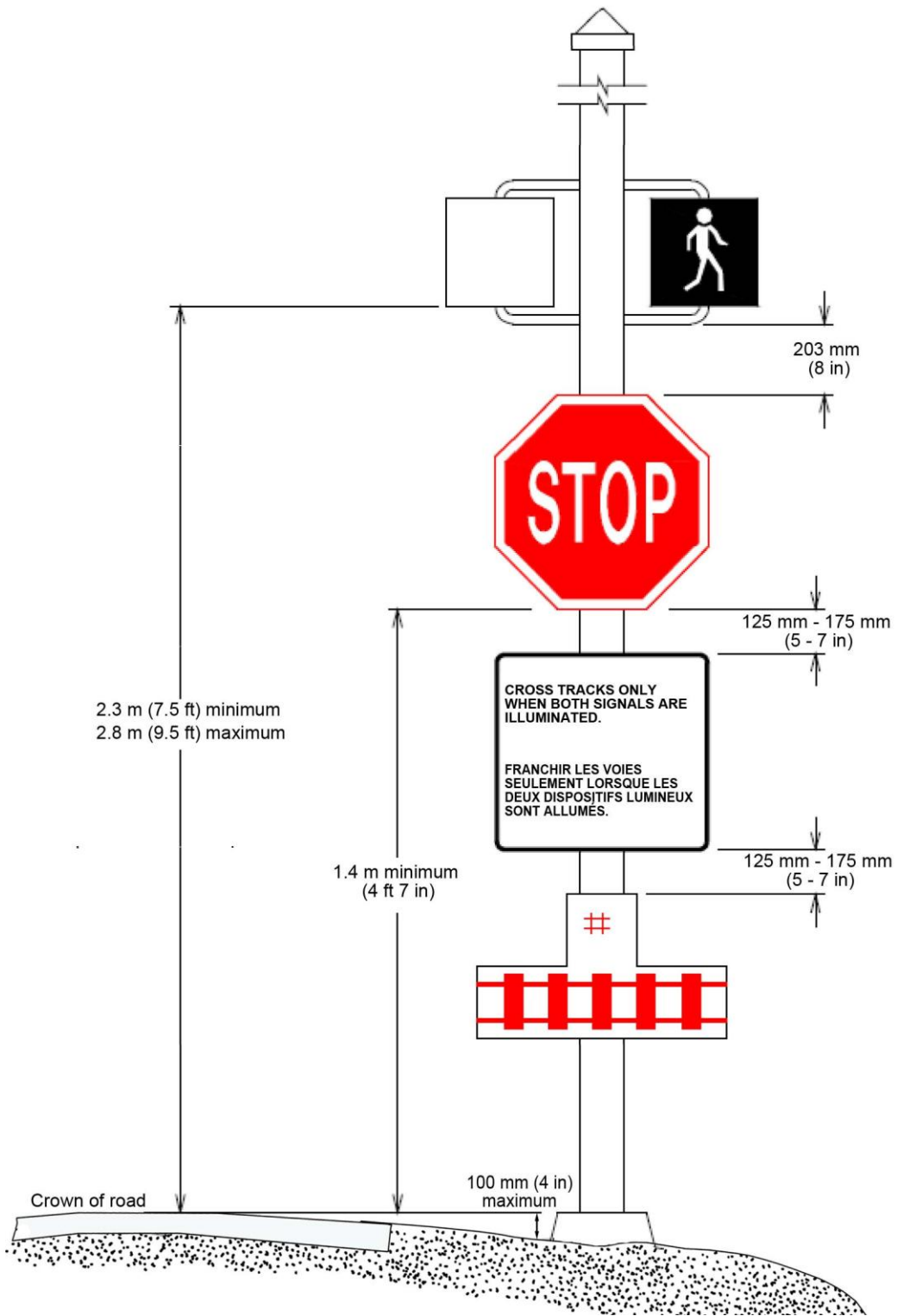

Figure C-2 – Instruction Sign



**APPENDIX D – WHISTLING CESSATION**

**Table D-1 – Requirements for Warning Systems at Public Grade Crossings within an Area without Whistling**

	Column A		Column B	
Railway Design Speed	Grade Crossings for Vehicle Use		Grade Crossings For Sidewalks, Paths, or Trails with the centreline no closer than 3.6 m (12 ft) to a warning signal for vehicles	
	No. of Tracks		No. of Tracks	
	1	2 or more	1	2 or more
<b>Column 1</b>	<b>Column 2</b>	<b>Column 3</b>	<b>Column 4</b>	<b>Column 5</b>
1 – 25 km/h (15 mph)	FLB	FLB	No warning system requirement	No warning system requirements
25 – 81 km/h (16 – 50 mph)	FLB	FLB & G	FLB	FLB & G
Over 81 km/h (50 mph)	FLB & G	FLB & G	FLB & G	FLB & G

*Legend :*  
 FLB is a warning system consisting of flashing lights and a bell.  
 FLB & G is a warning system consisting of flashing lights, a bell and gates

**Figure D-1 – prescribed area for whistling cessation as per article 23.1 of the RSA**

